

**POMPE A CILINDRATA
VARIABILE
VARIABLE DISPLACEMENT
PUMPS**

PPV

**INDICE
INDEX**



**POMPE A
CILINDRATA
VARIABILE
VARIABLE
DISPLACEMENT
PUMPS**

**Codifica versioni
Versions coding**.....pag. 03

**Introduzione e dati tecnici
Introduction and technical
features**.....pag. 05

**Gamma PPV
PPV range**

PPV 60.....pag. 09

PPV 90-110....pag. 17

PPV 130.....pag. 25

**Regolatori LS-PE-PI-PW
LS-PE-PI-PW Controls**.....pag. 29

**Valvola di flussaggio
Flushing valve**.....pag. 33

**Regolatore portata costante
Constant flow control**.....pag. 34

**Applicazioni PPV tandem
Tandem PPV application**...pag. 35

**Ricambi
Spare parts**.....pag. 39

**Accessori
Accessories**.....pag. 41

14/10/2021

99765011110 Rev: AP

CODIFICA VERSIONI VERSIONS CODING

COME COMPORRE L'ORDINE / HOW TO ORDER

| | | | | |
|-----------------------------------|---|---|---|---|
| CODICE POMPA PUMP CODE | + | RACCORDO ASPIRAZIONE SUCTION FITTING | + | VERSIONE FLANGIA E ALBERO (solo versioni tandem cod. B=3 o 5) FLANGE AND SHAFT VERSION (only tandem versions code B=3 o 5) |
| 650XXXXXXXXX | | 15511200507 (pag. 39) | | 11465000100 (pag. 33) |
| 651XXXXXXXXX | | | | |

FFFSTBDDRRX

Famiglia / Family

| | | |
|------------|---|------------|
| FFF | ISO 7653 4 fori/holes ø 80 | 650 |
| | SAE C 4 fori/holes - ISO 3019-1 127-4 l=114.5 | 651 |

Albero / Shaft

| | | |
|----------|---------------------------|----------|
| S | DIN 5462 8x32x36 (ISO 14) | 1 |
| | SAE C - 14T 12/24 32-4 | 2 |

Porte / Ports

| | | |
|----------|------------|----------|
| T | BSPP (GAS) | 1 |
| | UNF | 5 |

Fondello posteriore / Rear cover

| | | | |
|----------|---|----------|----------|
| B | AX Assiale / Axial - (STANDARD) | 1 | |
| | RV Radiale verticale non passante - Radial/vertical standard | 2 | |
| | PV Radiale verticale passante - Radial/vertical thru shaft | 3 | (Tandem) |
| | RO Radiale orizzontale SAE non passante - SAE Radial/horizontal standard | 4 | |
| | PO Radiale orizzontale SAE passante - SAE Radial/horizontal thru shaft | 5 | (Tandem) |

Cilindrata / Displacement

| | | |
|-----------|--------|-----------|
| DD | 60 cc | 06 |
| | 90 cc | 09 |
| | 110 cc | 11 |
| | 130 cc | 13 |

Regolatore / Control

| | | |
|-----------|---|-----------|
| RR | LS Load sensing | LS |
| | Pressione idraulica / Hydraulic pressure | PI |
| | Pressione elettrica / Electric pressure | PE |
| | Regolatore a potenza costante / Power control | PW |

Rotazione - Limitazione cilindrata Rotation - Displacement adjustment

| | | | |
|----------|---|----------|--------------|
| X | DESTRA nessuna limitazione / RIGHT no adjustment | 1 | |
| | DESTRA con limitazione / RIGHT with adjustment | 2 | (Adjustable) |
| | SINISTRA nessuna limitazione / LEFT no adjustment | 6 | |
| | SINISTRA con limitazione / LEFT with adjustment | 7 | (Adjustable) |

La versione **ADJUSTABLE**, prevede una vite di regolazione posteriore che limita la cilindrata della pompa a valori inferiori a quella nominale.
The **ADJUSTABLE** version consists of a rear setting screw that limits the displacement of the pumps to lower values than the nominal one.

POMPE A CILINDRATA VARIABILE VARIABLE DISPLACEMENT PUMPS

FAMIGLIA
FAMILY

PPV 60
PPV 90
PPV 110
PPV 130

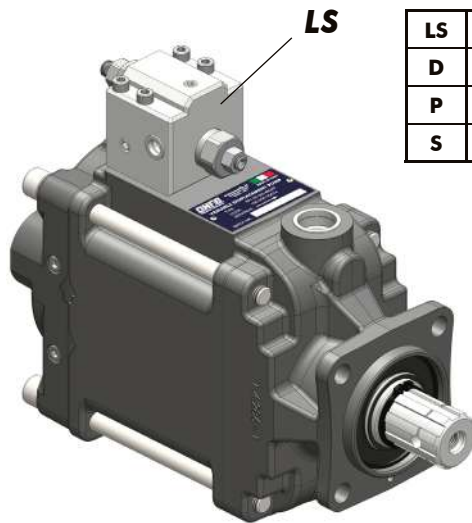

| | |
|----|--------------------------|
| LS | BLOCCHETTO LS / LS BLOCK |
| D | DRENAGGIO / DRAIN |
| P | PRESSIONE / PRESSURE |
| S | ASPIRAZIONE / SUCTION |

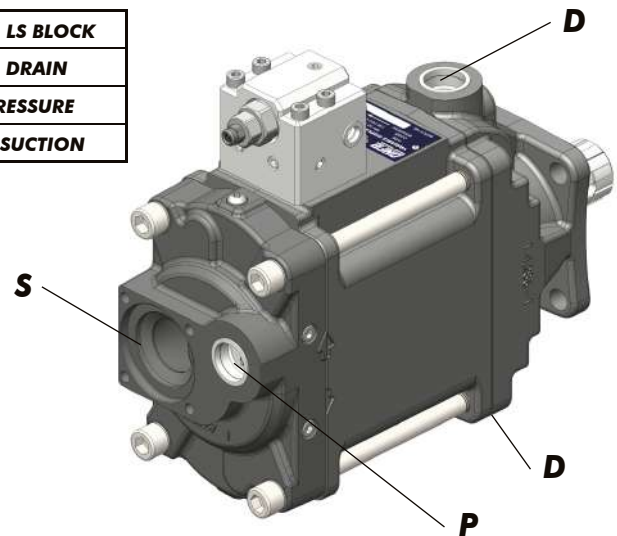

La pompa a pistoni assiali a cilindrata variabile OMFB è di tipo a piatto oscillante. La cilindrata della pompa dipende dalla corsa dei pistoni pompanti, che a sua volta dipende dall'inclinazione del piatto oscillante. La pompa all'avviamento si trova in cilindrata massima per effetto di due molle che spingono il piatto oscillante. La cilindrata della pompa viene ridotta agendo su due pistoni comandati idraulicamente in grado di vincere la forza delle molle. Un corpo cilindri ruota solidale con l'albero e costringe i pistoni a ruotare anch'essi alla stessa velocità dell'albero ed a compiere il percorso circolare sul piatto oscillante che ne provoca il movimento alternativo. La pompa in questo modo è in grado di erogare portata dal valore massimo fino ad un valore nullo. La variazione della cilindrata è comandata dal regolatore che si trova montato sulla pompa stessa. Sono pompe adatte a funzionare in circuito aperto. Permettono di avere tempi di reazione brevi e, grazie alla loro larghezza ridotta, il montaggio diretto sulle prese di forza (PTO) dei veicoli commerciali. In fase d'ordine è necessario specificare il senso di rotazione della pompa.

The OMFB variable displacement axial piston pump has got a swash plate. The displacement of the pump depends on the stroke of the pistons, which is determined by the inclination of the swash plate. At the start, the pump is at its maximum displacement position because of the springs pushing against the swash plate. The displacement of the pump is reduced by means of two pistons hydraulically operated that win the force of the springs. The cylinders block rotates together with the shaft forcing the pistons to rotate at the same speed of the shaft and make a circular path on the swash plate that causes the reciprocating movement. In this way, the pump is able to deliver from the maximum to zero flow rate. The variation of the displacement is controlled by a regulator, which is fitted on the pump itself. These pumps are designed to operate in open circuit. They allow very quick reaction time and thanks to its compact size they can be coupled directly onto PTO's of commercial vehicles. When ordering please specific the required direction of rotation.

14/10/2021

99765011110 Rev: AP

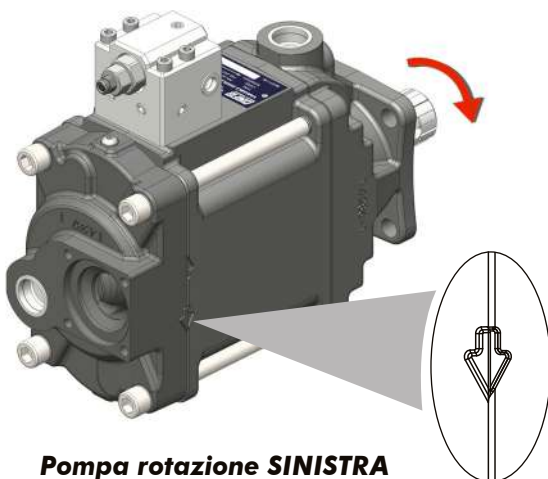

Pompa rotazione SINISTRA
LEFT Hand rotating pump

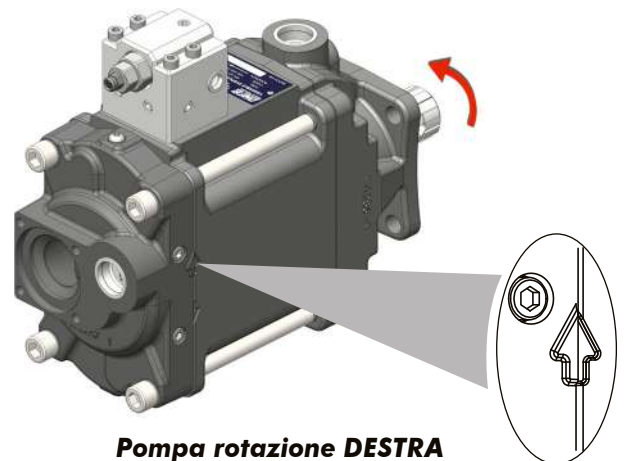

Pompa rotazione DESTRA
RIGHT Hand rotating pump

pag.5

POMPE A CILINDRATA VARIABILE / VARIABLE DISPLACEMENT PUMPS

| DATI TECNICI / TECHNICAL FEATURES | PPV60 | PPV90 | PPV110 | PPV130 |
|--|------------------------|-------------------------------|------------------------|-------------------------------|
| Portata / Flow | 60 l/min. | 90 l/min. | 110 l/min. | 130 l/min. |
| Angolo di regolazione massima / Max. swash plate angle | 21,5° | | | |
| Pressione di lavoro / Working pressure | Continua Continuous | Intermittente Intermittent | Continua Continuous | Intermittente Intermittent |
| | 375 bar | 400 bar | 375 bar | 400 bar |
| Pressione d'ingresso assoluta necessaria nel circuito aperto Absolute inlet pressure required in open circuit | 0,85 bar | | | |
| Pressione massima ammissibile sul corpo (statica/dinamica) Max. permissible housing pressure (static/dynamic) | 1 bar | 3 bar | | |
| Pressione d'ingresso massima ammissibile Max. permissible inlet pressure (static/dynamic) | 2 bar | | | |
| Numero di giri max. con angolo di regolazione max. a una pressione d'ingresso assoluta di 1 bar. / Max. speed during suction operation and max. swash plate angle at 1 bar abs. Inlet pressure | 2500 rpm | 2300 rpm | 2200 rpm | 2100 rpm |
| Numero giri max. in annullamento e pressione d'ingresso assoluta 1 bar. / Max. speed with zero stroke and 1 bar abs. Inlet pressure | 3000 rpm | | | |
| Numero di giri minimo in funzionamento continuo Min. speed in continuous operation | 500 rpm | | | |
| Coppia motrice necessaria a 100 bar Required drive torque at 100 bar | 100 Nm | 150 Nm | 185 Nm | 220 Nm |
| Potenza motrice a 250 bar e 2.000 rpm Drive power at 250 bar and 2000 rpm | 53 kW | 80 kW | 100 kW | 145 kW |
| Peso / Weight | 24 Kg | 29 Kg | 30 Kg | 27 Kg |

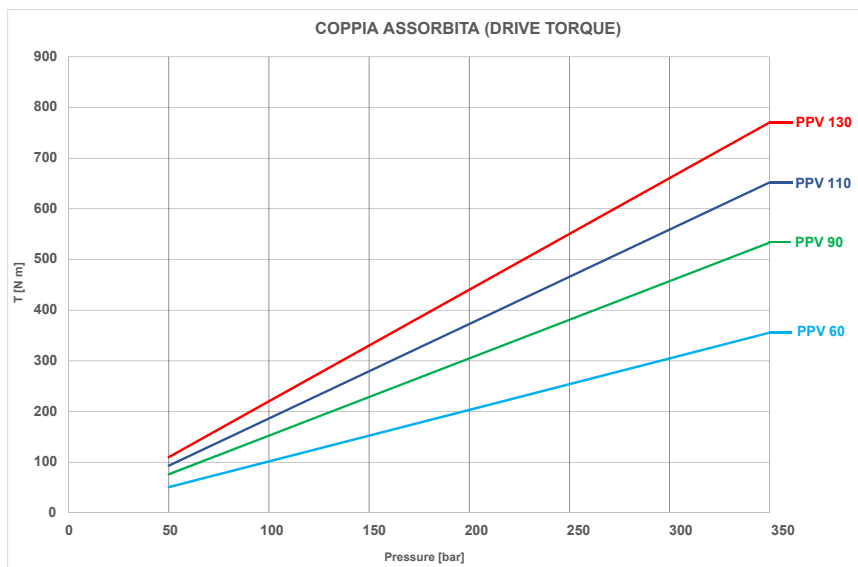

La versione **ADJUSTABLE**, prevede una vite di regolazione posteriore che limita la cilindrata massima della pompa a valori inferiori a quella nominale.

The **ADJUSTABLE** version consists of a rear setting screw that limits the max. displacement of the pumps to lower values than the nominal one.

CILINDRATA / DISPLACEMENT 60cc

| | |
|---|--------------------------|
| Campo regolazione cilindrata Displacement limitation range | 40 - 60 cm ³ |
| Limitazione della cilindrata Displacement limitation range | 4,3 cm ³ /rev |

CILINDRATA / DISPLACEMENT 90cc

| | |
|---|--------------------------|
| Campo regolazione cilindrata Displacement limitation range | 55 - 90 cm ³ |
| Limitazione della cilindrata Displacement limitation range | 5,7 cm ³ /rev |

CILINDRATA / DISPLACEMENT 110cc

| | |
|---|--------------------------|
| Campo regolazione cilindrata Displacement limitation range | 85 - 110 cm ³ |
| Limitazione della cilindrata Displacement limitation range | 6,6 cm ³ /rev |

CILINDRATA / DISPLACEMENT 130cc

| | |
|---|--------------------------|
| Campo regolazione cilindrata Displacement limitation range | 90 - 130 cm ³ |
| Limitazione della cilindrata Displacement limitation range | 12 cm ³ /rev |

POMPE A CILINDRATA VARIABILE / VARIABLE DISPLACEMENT PUMPS

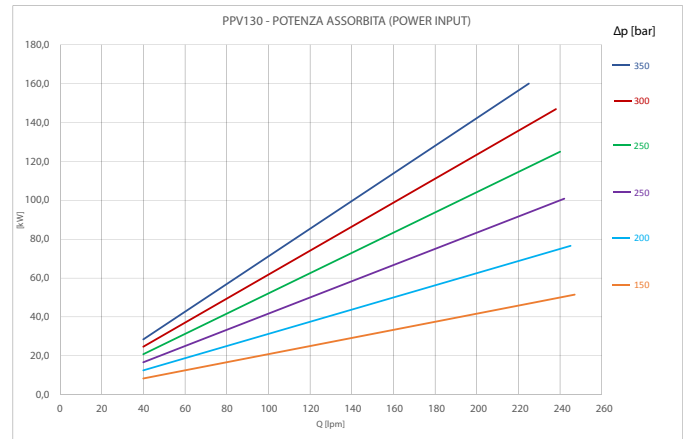
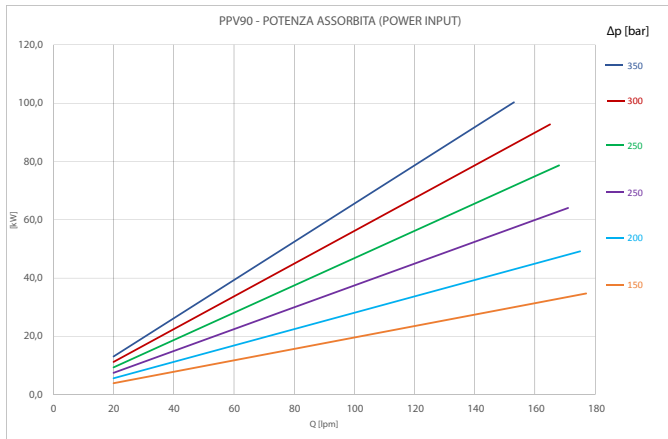
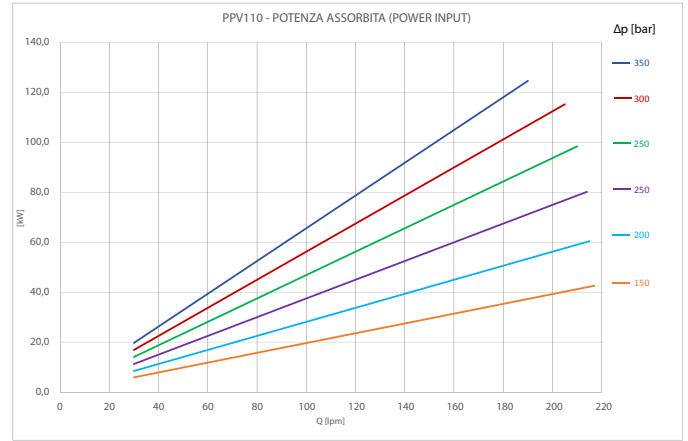
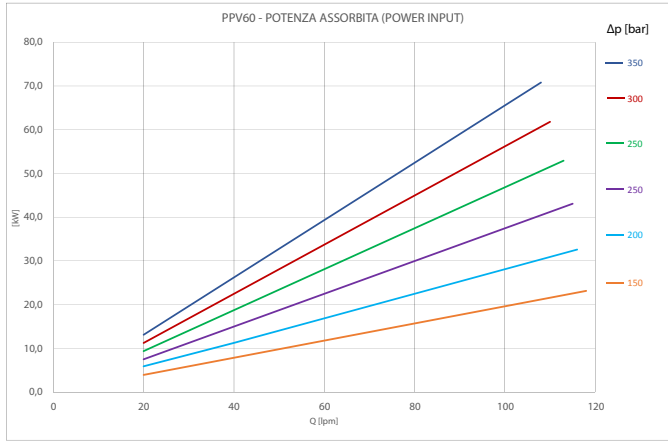

| | | | | | |
|--|---|----------------------|--------|-------|------|
| Fluido idraulico / Fluid | Minerale o sintetico compatibile con guarnizioni: Mineral or synthetic compatible with the following seals: HNBR | | | | |
| Temp. consentita / Allowed temperature | -25 +80 °C | | | | |
| Viscosità cinematica consigliata Kinematic viscosity suggested | T media ambiente (°C) Average ambient temp. (°C) | < -40 | -40÷10 | 10÷35 | > 35 |
| | VG (cSt = mm ² /s) | 16 | 22 | 32 | 46 |
| Viscosità cinematica ottimale di esercizio / Optimal kinematic viscosity | | VG= 10 cSt ÷ 100 cSt | | | |
| Viscosità cinematica max consentita all'avviamento / Max kinematic viscosity suggested at the start-up | | VG= 750 cSt | | | |
| Indice di viscosità consigliato / Viscosity index suggested | | VI > 100 | | | |

| Filtrazione / Filtration | | | |
|--|----------|------------|----------|
| Pressione di lavoro / Working pressure (bar) | ΔP<140 | 140<ΔP<210 | ΔP>210 |
| Contaminazione classe NAS 1638 Contamination class NAS 1638 | 9 | 8 | 7 |
| Contaminazione classe ISO 4406-1999 Contamination class ISO 4406-1999 | 20/18/15 | 19/17/14 | 18/16/13 |
| Da ottenere con filtro β _x >75 secondo ISO 16889 To be obtained with filter β _x >75 according ISO 16889 | 10 μm | | |

Grandezze nominali
Nominal values

Portata
Flow

$$Q [lpm] = \frac{V \cdot n \cdot \eta_V}{1000}$$

Coppia motrice
Torque

$$T [N \cdot m] = \frac{V \cdot \Delta p}{20 \cdot \pi \cdot \eta_{hm}}$$

Potenza motrice
Power

$$P [kW] = \frac{2 \cdot \pi \cdot T \cdot n}{60000} = \frac{Q \cdot \Delta p}{600 \cdot \eta_{tot}}$$

FORMULE / FORMULAS

V = cilindrata [cm³ / rev] / displacement

Δp = salto di pressione [bar] / pressure drop

n = velocità di rotazione [rpm] / rotation speed

η_V = rendimento volumetrico / volumetric efficiency

η_{hm} = rendimento idro-meccanico / hydro-mechanic efficiency

η_{tot} = η_V x η_{hm} = rendimento totale / overall efficiency

pag.7



O.M.F.B. S.p.a. Hydraulic Components

We reserve the right to make any changes without notice.

Edition 2016.08 No reproduction, however partial, is permitted.

Via Cave, 7/9 25050 Provaglio d'Iseo (Brescia) Italy Tel.: +39.030.9830611
Fax: +39.030.9839207-208 Internet:www.omfb.it e-mail:contatti@omfb.it

COMPANY WITH
QUALITY SYSTEM
CERTIFIED BY DNV GL
= ISO 9001:2015 =

14/10/2021

99765011110 Rev: AP

POMPA A CILINDRATA VARIABILE VARIABLE DISPLACEMENT PUMP

PPV 60

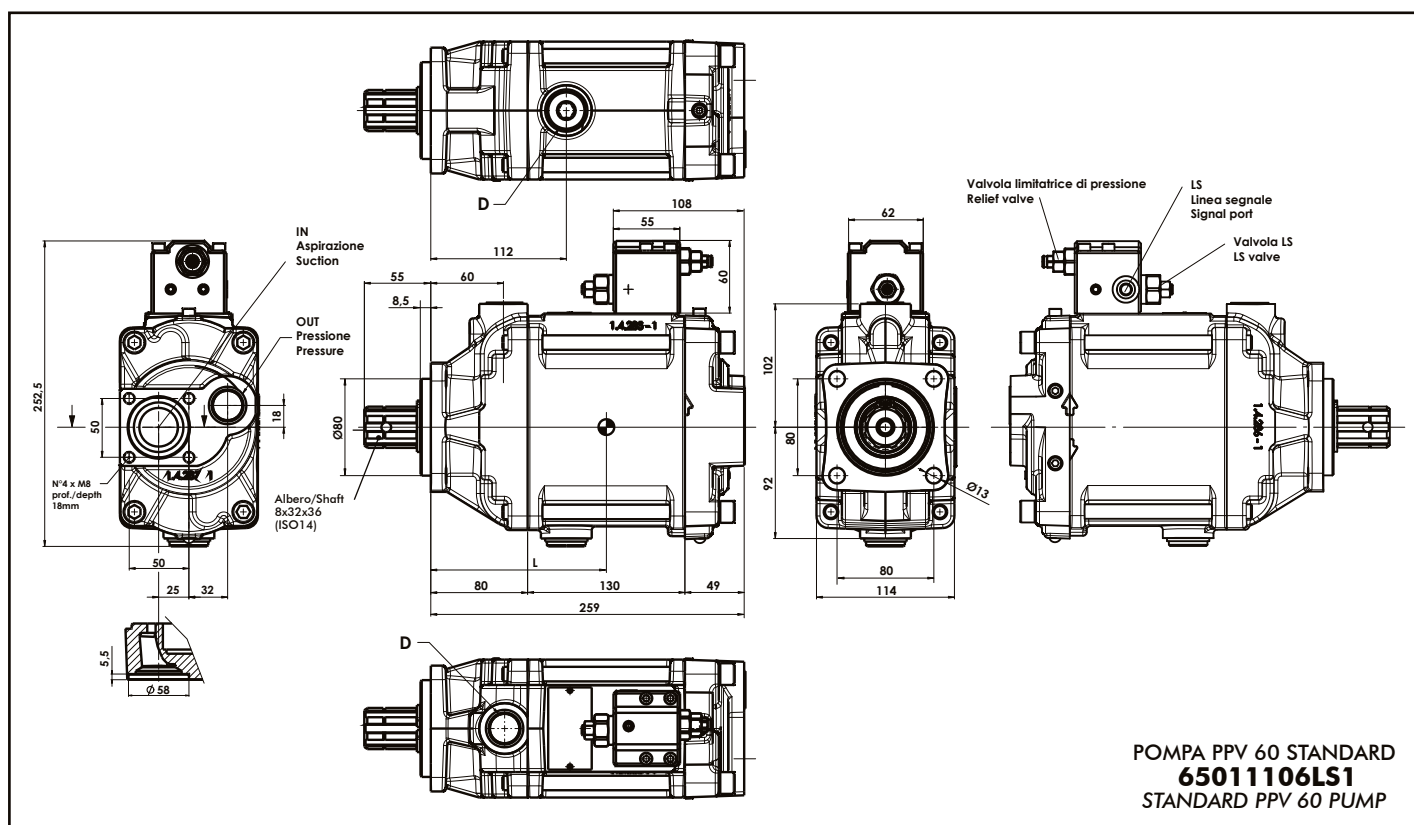

POMPA PPV 60 STANDARD
65011106LS1
STANDARD PPV 60 PUMP

14/10/2021

99765011110 Rev: AP

| | | FFFS1BDDRRX | FFFS5BDDRRX |
|------------|---|---------------------|-----------------|
| LS | BLOCCHETTO LS/ LS BLOCK | G 1/4 | |
| D | DRENAGGIO / DRAIN | G 3/4 | 1 1/16-12 UN-2B |
| OUT | PRESSIONE / PRESSURE | G 3/4 | 1 5/16-12 UN-2B |
| IN | ASPIRAZIONE / SUCTION Raccordo da ordinare separatamente Suction fitting to be ordered separately | Ø50 mm | |
| L | BARICENTRO / CENTER OF MASS | 145 mm circa/approx | |

pag.9



O.M.F.B. S.p.a. Hydraulic Components
We reserve the right to make any changes without notice.
Edition 2016.08 No reproduction, however partial, is permitted.
Via Cave, 7/9 25050 Provaglio d'Iseo (Brescia) Italy Tel.: +39.030.9830611
Fax: +39.030.9839207-208 Internet:www.omfb.it e-mail:contatti@omfb.it

COMPANY WITH
QUALITY SYSTEM
CERTIFIED BY DNV GL
= ISO 9001:2015 =

6501TBDDRRX

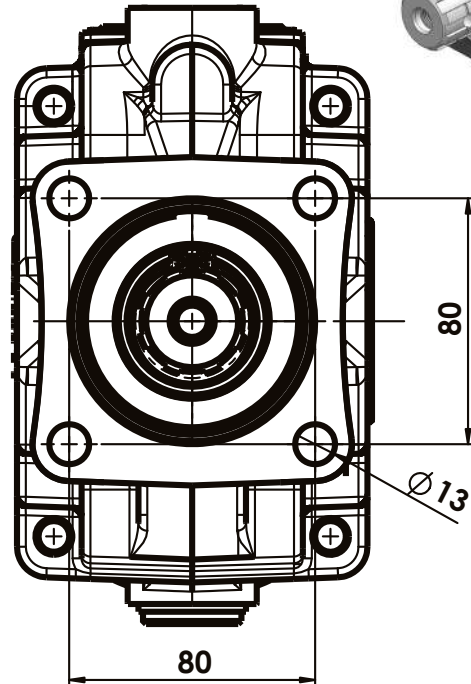
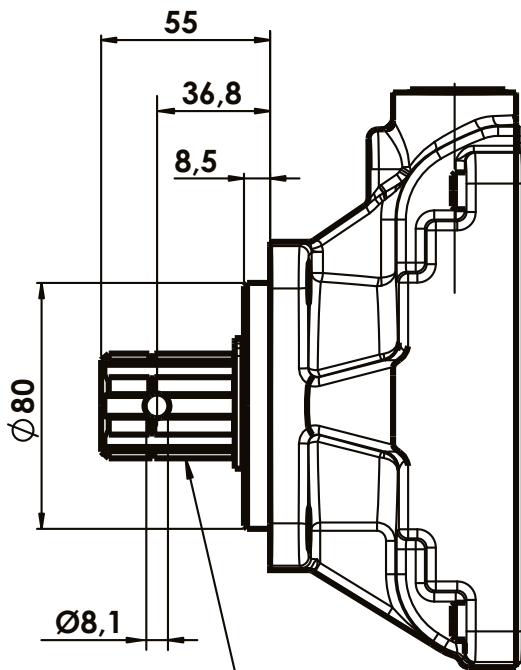

Albero/Shaft
8x32x36
(ISO 14)

COPPIA TRASMISSIBILE
MASSIMA 900Nm
MAX. TORQUE 900Nm

6512TBDDRRX

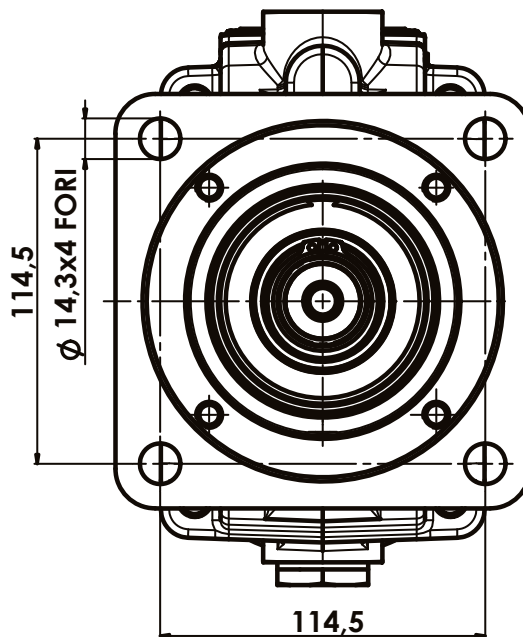
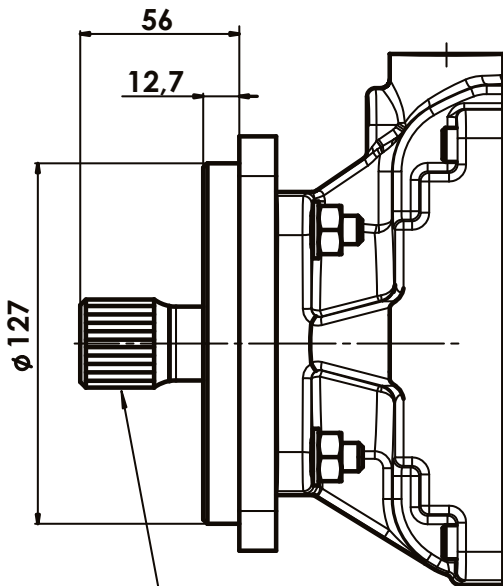

Albero/Shaft
SAE C-14T 12/24DP
(ISO 3019-1 32-4)

COPPIA TRASMISSIBILE
MASSIMA 640Nm
MAX. TORQUE 640Nm

FFFST 1 DDDR 1

Rotazione destra/Right rotation
Senza limitazione/No adjustment

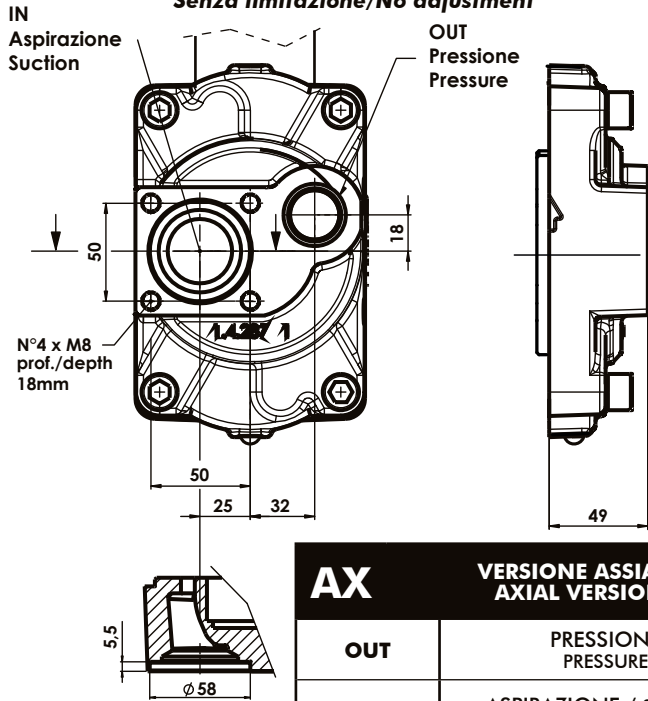

FFFST 1 DDDR 6

Rotazione sinistra/Left rotation
Senza limitazione/No adjustment

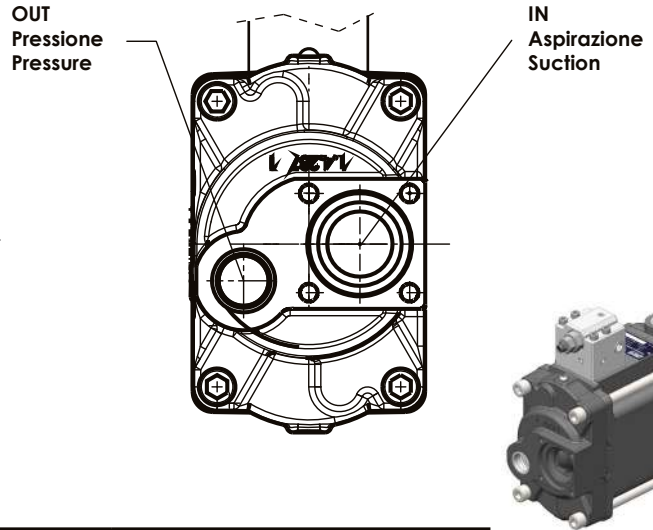

| AX | VERSIONE ASSIALE AXIAL VERSION | FFFS1 BDDRRX | FFFS5 BDDRRX |
|-----|---|--------------|-----------------|
| OUT | PRESSIONE PRESSURE | G 3/4 | 1 5/16-12 UN-2B |
| IN | ASPIRAZIONE / SUCTION Raccordo da ordinare separatamente Suction fitting to be ordered separately | Ø50mm | |

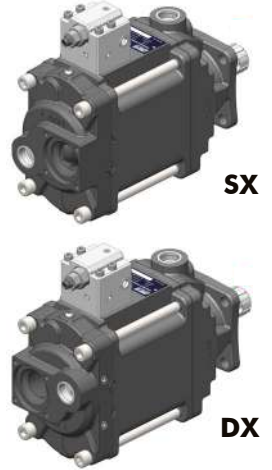

FFFST 1 DDDR 2

Rotazione destra/Right rotation
Con limitazione/With adjustment

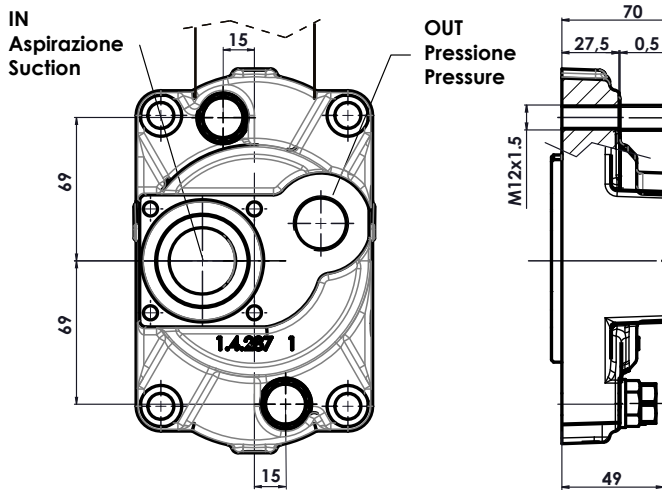

FFFST 1 DDDR 7

Rotazione sinistra/Left rotation
Con limitazione/With adjustment

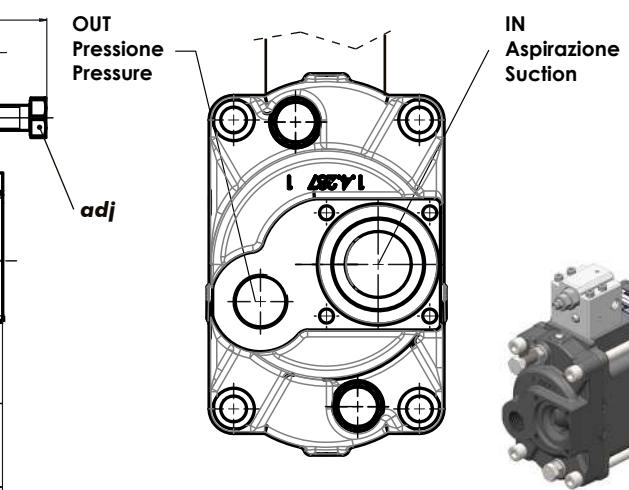

| AX | VERSIONE ASSIALE AXIAL VERSION | FFFS1 BDDRRX | FFFS5 BDDRRX |
|-----|---|--------------|-----------------|
| OUT | PRESSIONE PRESSURE | G 3/4 | 1 5/16-12 UN-2B |
| IN | ASPIRAZIONE / SUCTION Raccordo da ordinare separatamente Suction fitting to be ordered separately | Ø50mm | |

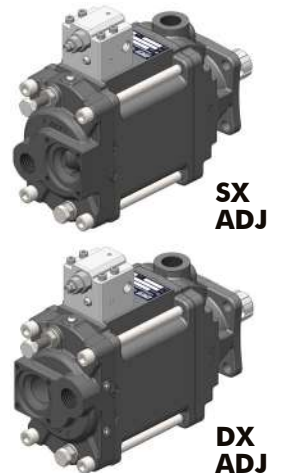

99765011110 Rev: AP 14/10/2021

FFFST 2 DDDR 1

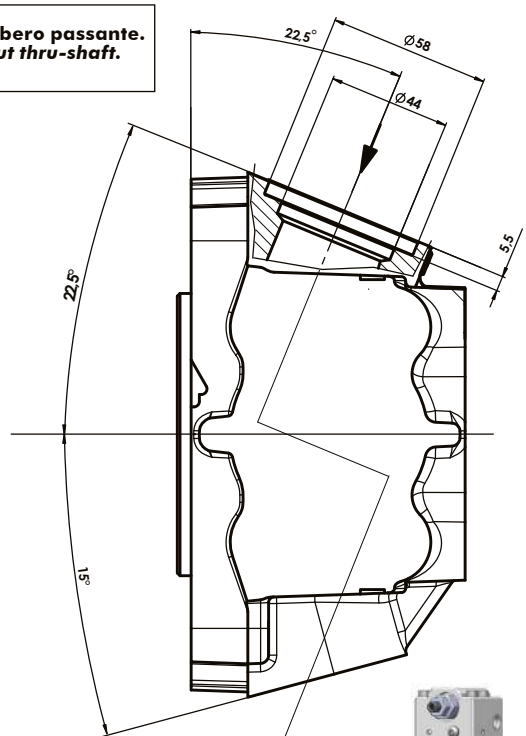
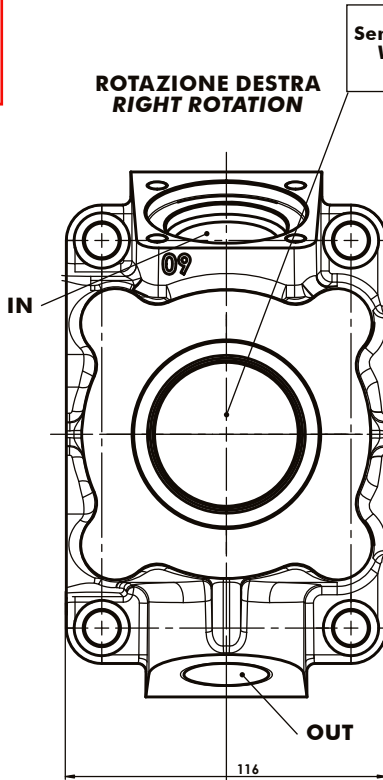
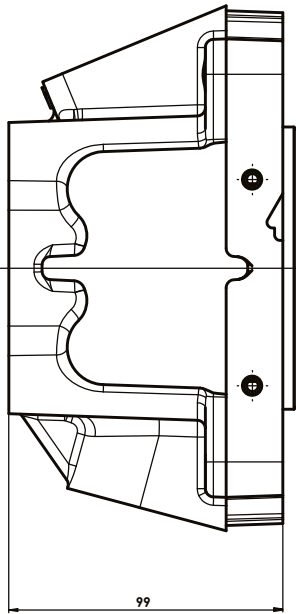

| RV VERSIONE RADIALE VERTICALE SENZA ALBERO PASSANTE VERTICAL RADIAL VERSION WITHOUT THRU-SHAFT | | FFFST 1 BDDRRX | FFFST 5 BDDRRX |
|--|---|----------------|-----------------|
| OUT | PRESSIONE / PRESSURE | G 1 | 1 5/16-12 UN-2B |
| IN | ASPIRAZIONE / SUCTION Raccordo da ordinare separatamente Suction fitting to be ordered separately | Ø50mm | |

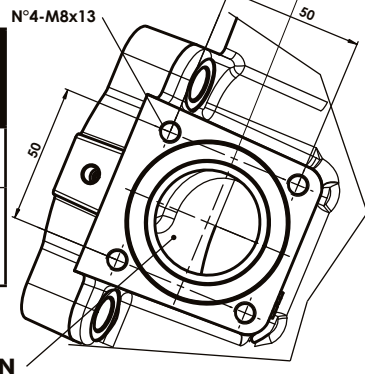

FFFST 2 DDDR 6

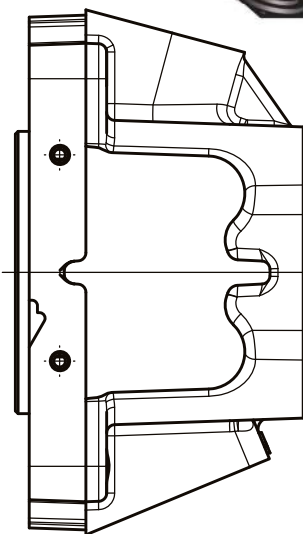
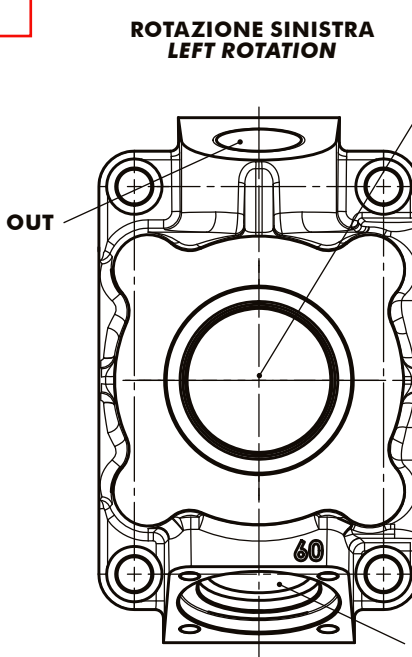
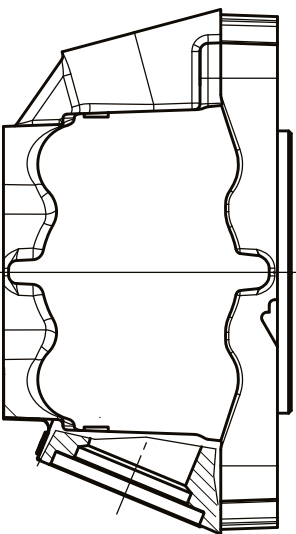

FFFST 3 DDDR 1

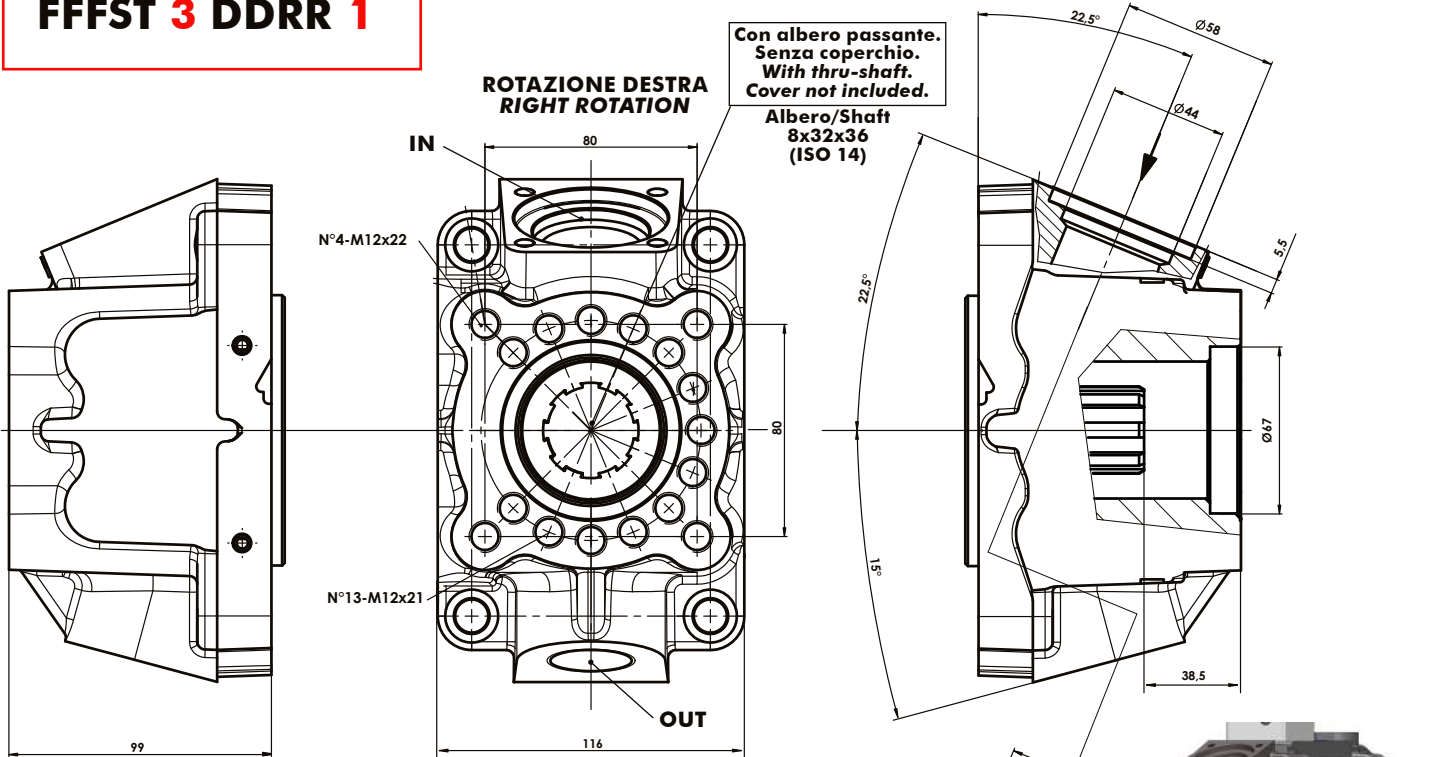

| PV | | FFFST 1 BDDR X | FFFST 5 BDDR X |
|---|---|----------------|-----------------|
| VERSIONE RADIALE VERTICALE CON ALBERO PASSANTE VERTICAL RADIAL VERSION WITH THRU-SHAFT | | | |
| OUT | PRESSIONE / PRESSURE | G 1 | 1 5/16-12 UN-2B |
| IN | ASPIRAZIONE / SUCTION Raccordo da ordinare separatamente Suction fitting to be ordered separately | Ø50mm | |

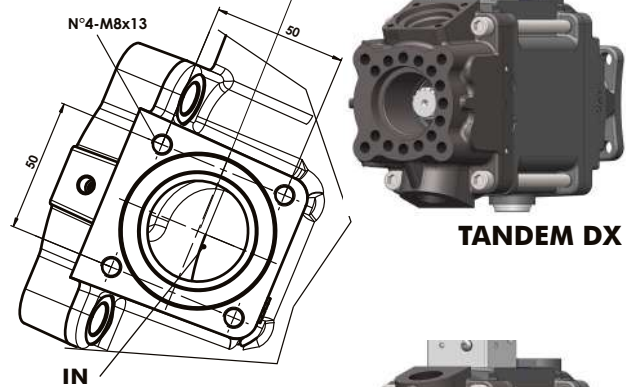

FFFST 3 DDDR 6

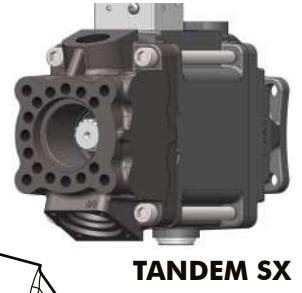
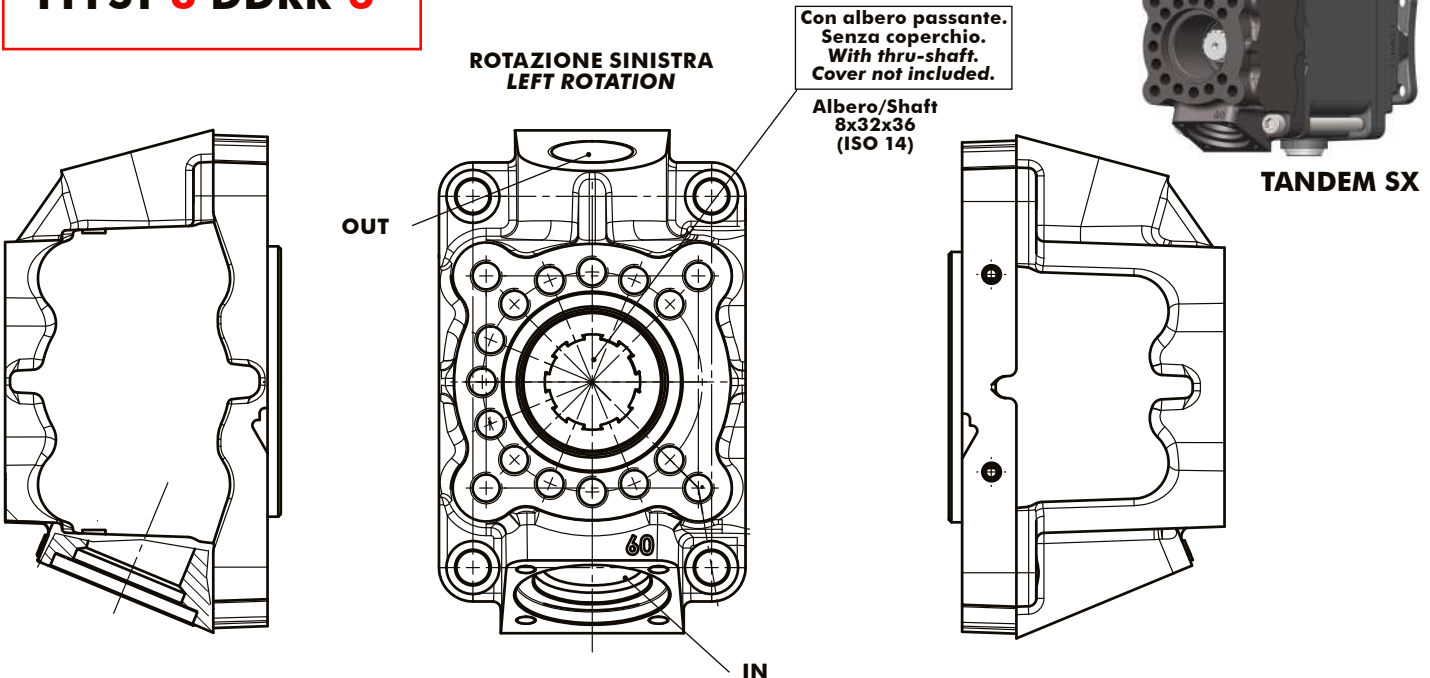

14/10/2021

99765011110 Rev: AP

FFFST 4 DDDR 1

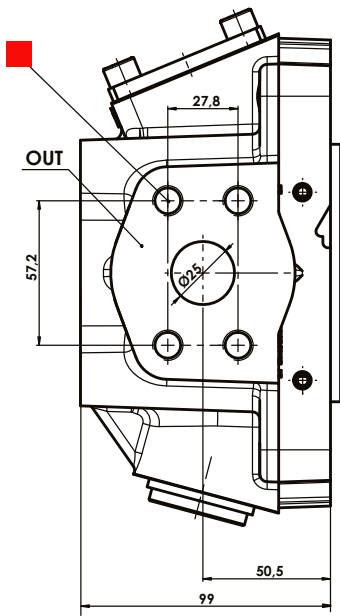

ROTAZIONE DESTRA
RIGHT ROTATION

Senza albero passante.
Without thru-shaft.

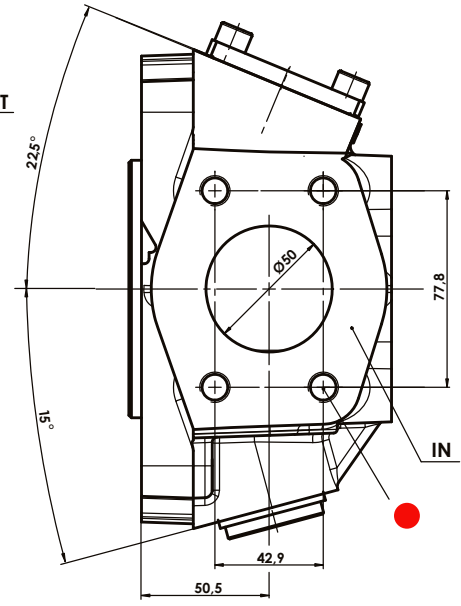
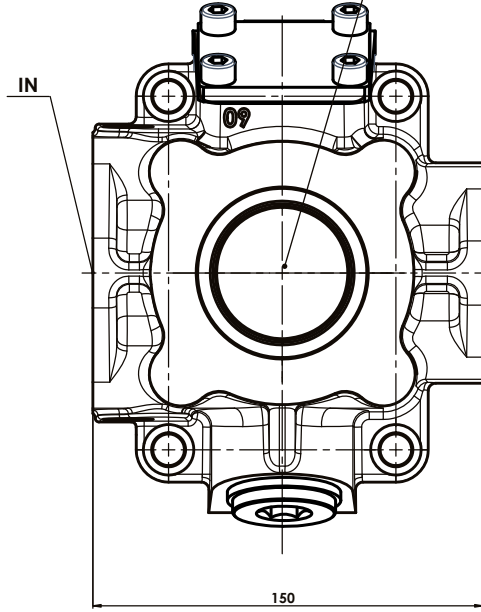

| RO | | VERSIONE RADIALE ORIZZONTALE SAE SENZA ALBERO PASSANTE HORIZONTAL RADIAL SAE VERSION WITHOUT THRU-SHAFT | FFFST 1 BDDRRX | FFFST 5 BDDRRX |
|-----|------------------------|--|----------------|----------------|
| OUT | PRESSIONE PRESSURE | 1" SAE 6000 | ■ M12 | ■ 7/16"UNC |
| IN | ASPIRAZIONE SUCTION | 2" SAE 3000 | ● M12 | ● 1/2"UNC |



FFFST 4 DDDR 6

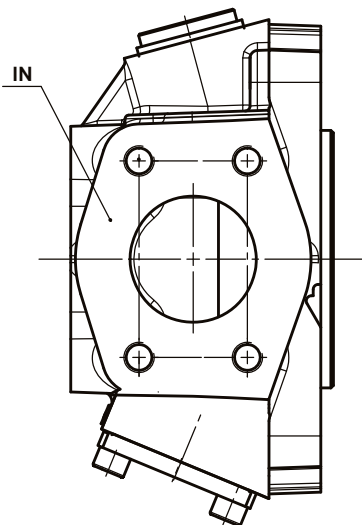

ROTAZIONE SINISTRA
LEFT ROTATION

Senza albero passante.
Without thru-shaft.

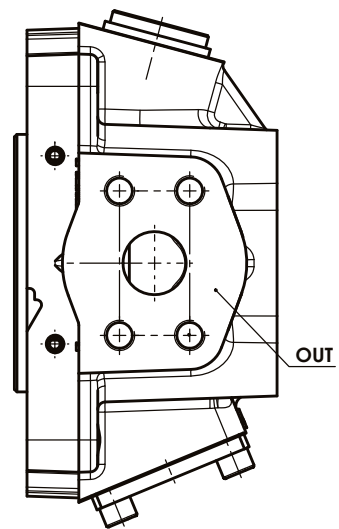
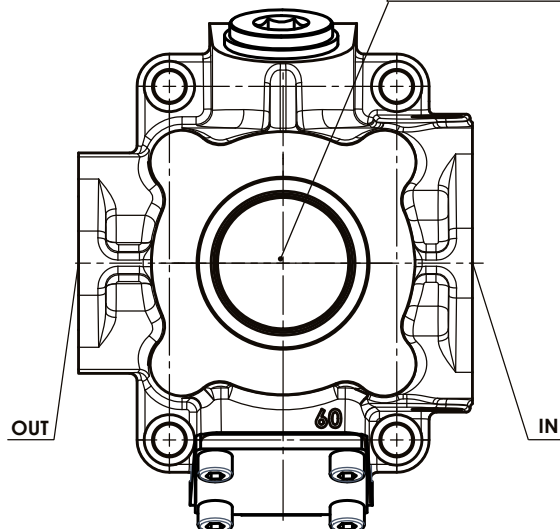

FFFST 5 DDDR 1

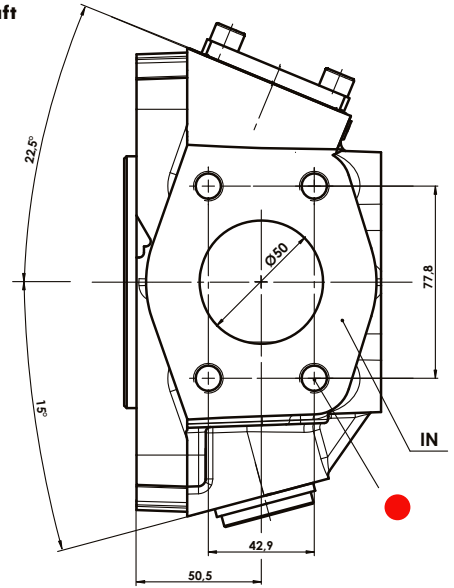
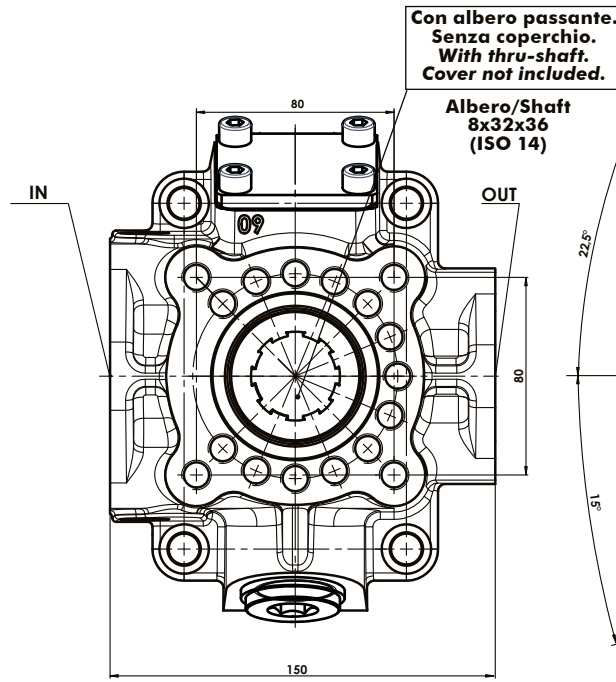
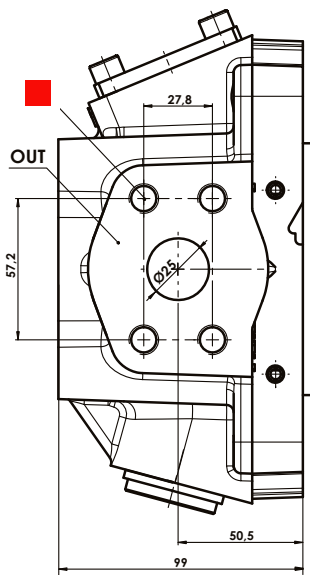

**ROTAZIONE DESTRA
RIGHT ROTATION**

TANDEM DX



TANDEM SX

| VERSIONE RADIALE ORIZZONTALE SAE CON ALBERO PASSANTE HORIZONTAL RADIAL SAE VERSION WITH THRU-SHAFT | | | FFFS1 BDDRRX | FFFS5 BDDRRX |
|---|------------------------|-----------------|--------------|--------------|
| OUT | PRESSIONE PRESSURE | 1" SAE 6000 | ■ M12 | ■ 1/2"UN |
| IN | ASPIRAZIONE SUCTION | 2 1/2" SAE 3000 | ● M12 | ● 1/2"UN |

FFFST 5 DDDR 6

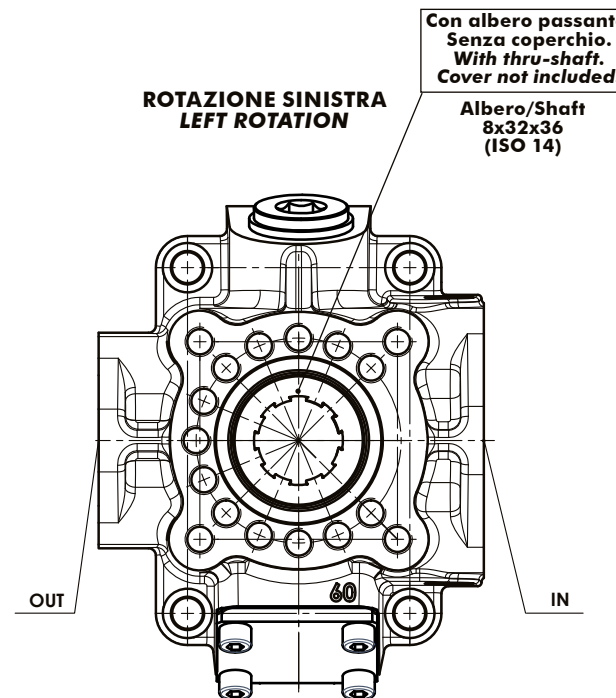
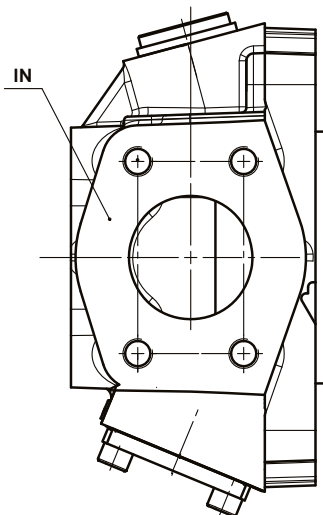

**ROTAZIONE SINISTRA
LEFT ROTATION**

14/10/2021

99765011110 Rev: AP

POMPE A CILINDRATA VARIABILE VARIABLE DISPLACEMENT PUMPS

PPV 90-110

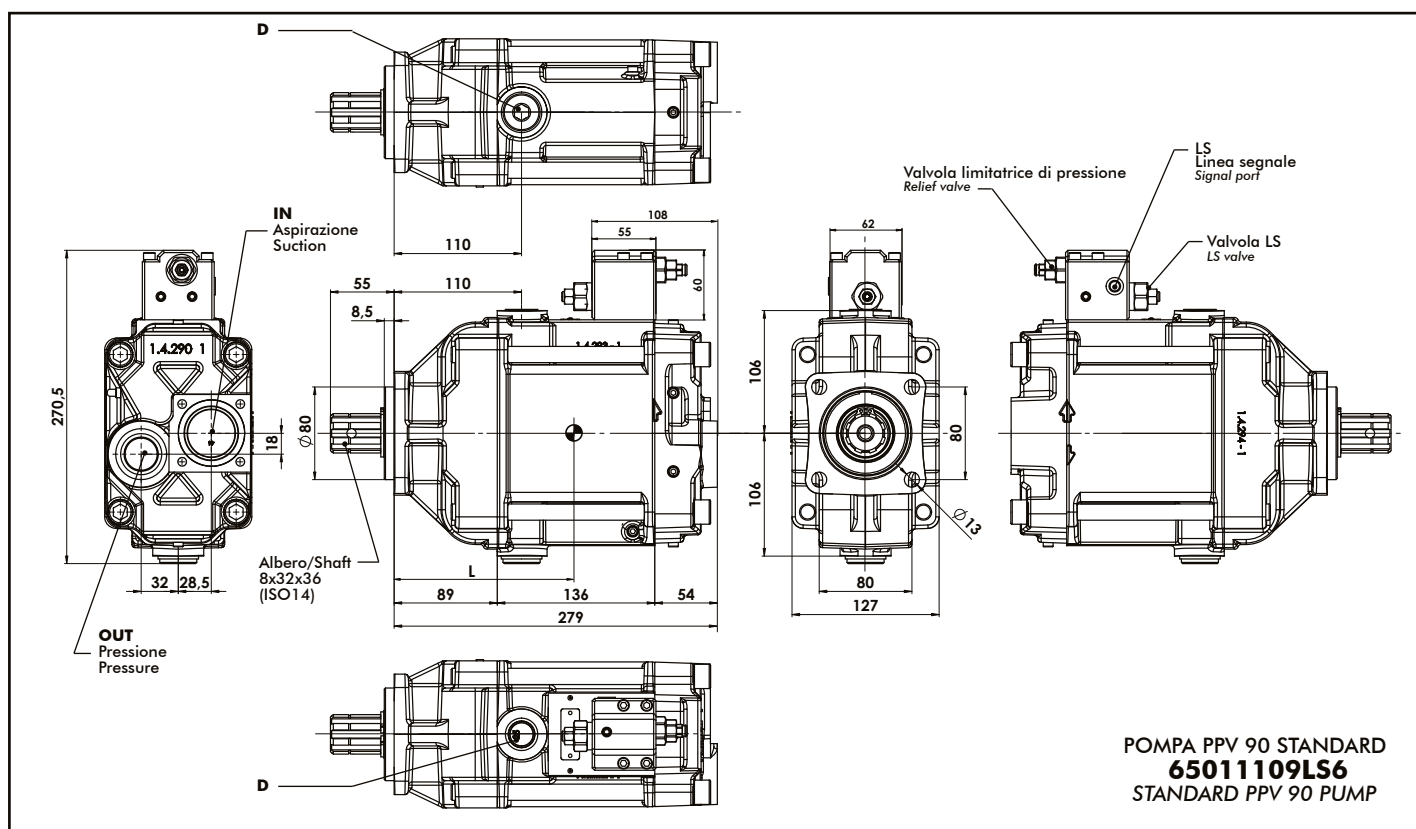
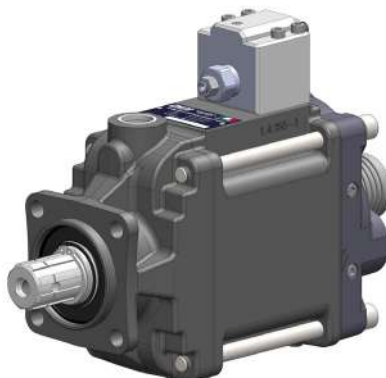

POMPA PPV 90 STANDARD
65011109LS6
STANDARD PPV 90 PUMP

14/10/2021

99765011110 Rev: AP

| | | FFFS1BDDRRX | FFFS5BDDRRX |
|------------|---|---------------------|--------------------|
| LS | BLOCCHETTO LS/ LS BLOCK | G 1/4 | |
| D | DRENAGGIO / DRAIN | G 3/4 | 1 1/16-12 UN-2B |
| OUT | PRESSIONE / PRESSURE | G 1 | 1 5/16-12 UN-2B |
| IN | ASPIRAZIONE / SUCTION Raccordo da ordinare separatamente Suction fitting to be ordered separately | Ø50 mm | |
| L | BARICENTRO / CENTER OF MASS | 148 mm circa/approx | |

pag.17



O.M.F.B. S.p.a. Hydraulic Components
We reserve the right to make any changes without notice.
Edition 2016.08 No reproduction, however partial, is permitted.
Via Cave, 7/9 25050 Provaglio d'Iseo (Brescia) Italy Tel.: +39.030.9830611
Fax: +39.030.9839207-208 Internet:www.omfb.it e-mail:contatti@omfb.it

COMPANY WITH
QUALITY SYSTEM
CERTIFIED BY DNV GL
= ISO 9001:2015 =

6501TBDDRRX

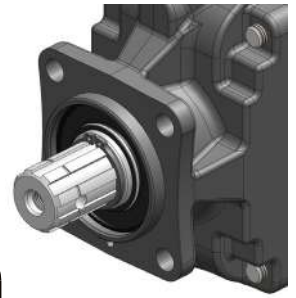
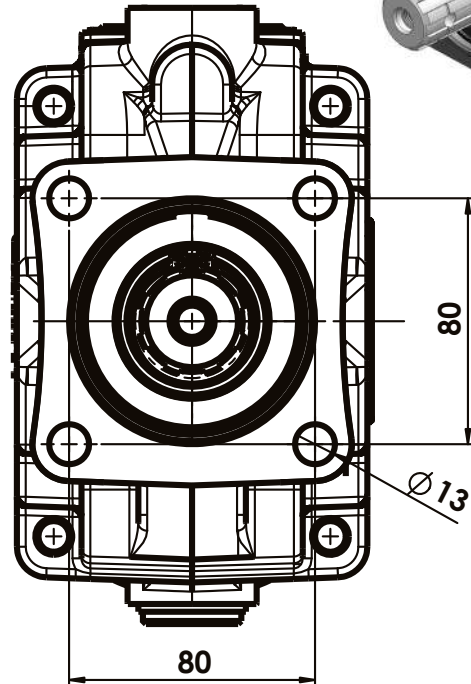
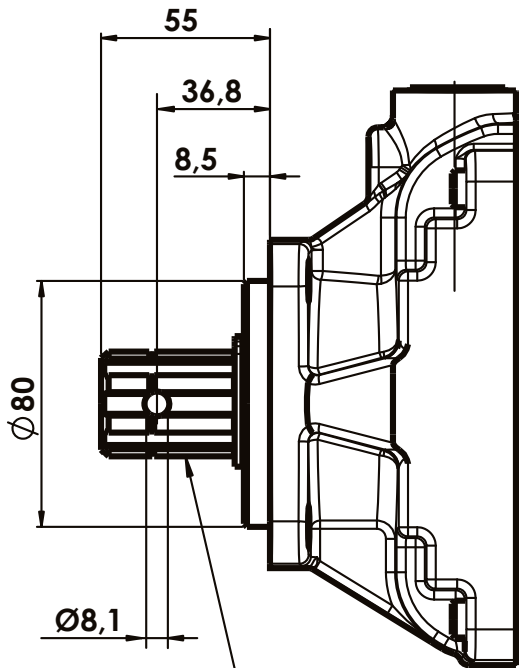

Albero/Shaft
8x32x36
(ISO 14)

COPPIA TRASMISSIBILE
MASSIMA 900Nm
MAX. TORQUE 900Nm

6512TBDDRRX

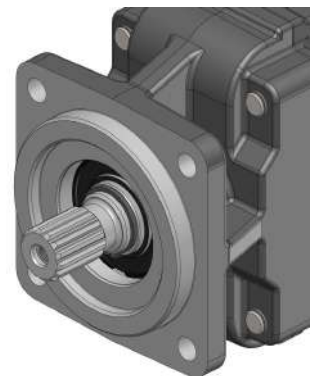
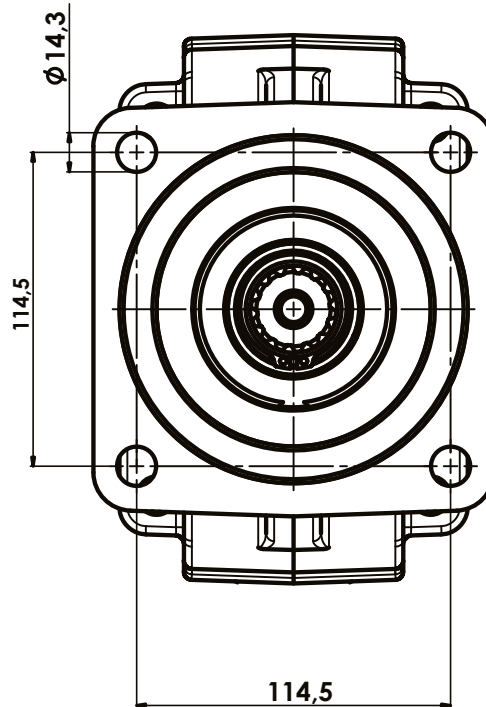
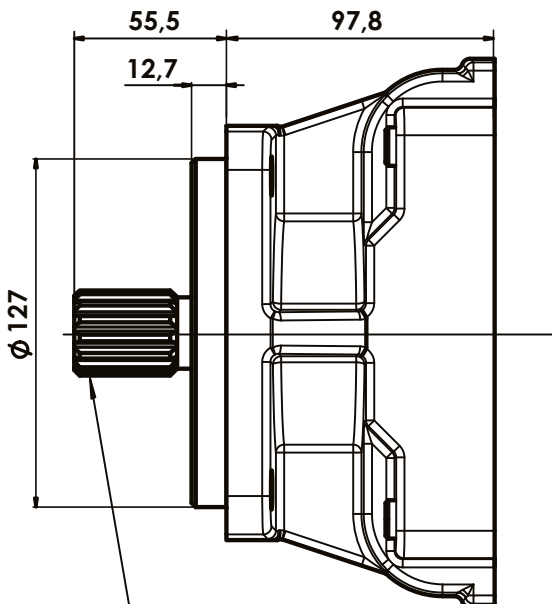

Albero/Shaft
SAE C-14T 12/24DP
(ISO 3019-1 32-4)

COPPIA TRASMISSIBILE
MASSIMA 640Nm
MAX. TORQUE 640Nm

FFFST 1 DDDR 1

Rotazione destra/Right rotation
Senza limitazione/No adjustment

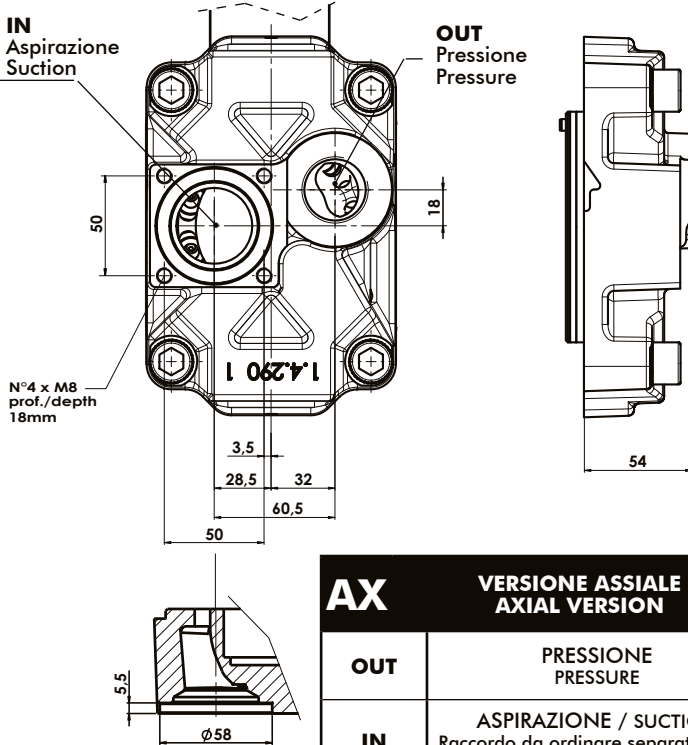

FFFST 1 DDDR 6

Rotazione sinistra/Left rotation
Senza limitazione/No adjustment

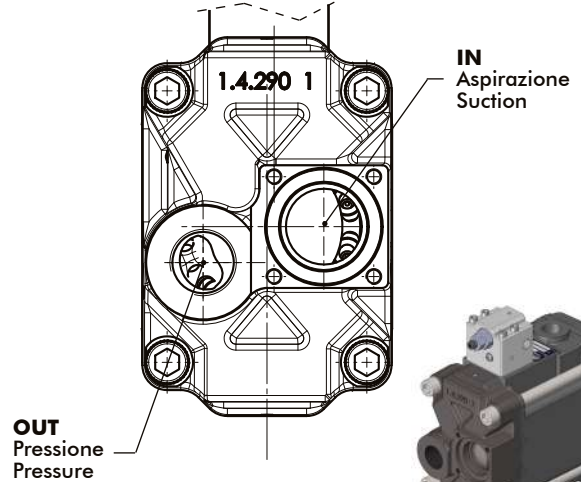

| AX | VERSIONE ASSIALE AXIAL VERSION | FFFST 1 BDDRRX | FFFST 5 BDDRRX |
|-----|---|----------------|-----------------|
| OUT | PRESSIONE PRESSURE | G 1 | 1 5/16-12 UN-2B |
| IN | ASPIRAZIONE / SUCTION Raccordo da ordinare separatamente Suction fitting to be ordered separately | Ø50mm | |

FFFST 1 DDDR 2

Rotazione destra/Right rotation
Con limitazione/With adjustment

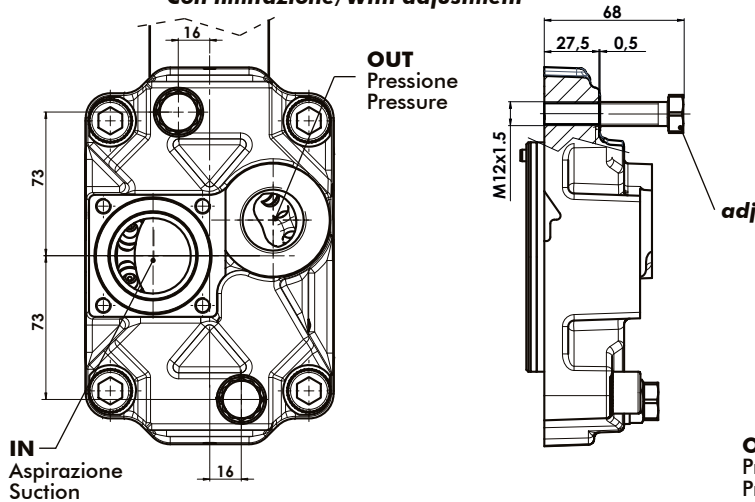

FFFST 1 DDDR 7

Rotazione sinistra/Left rotation
Con limitazione/With adjustment

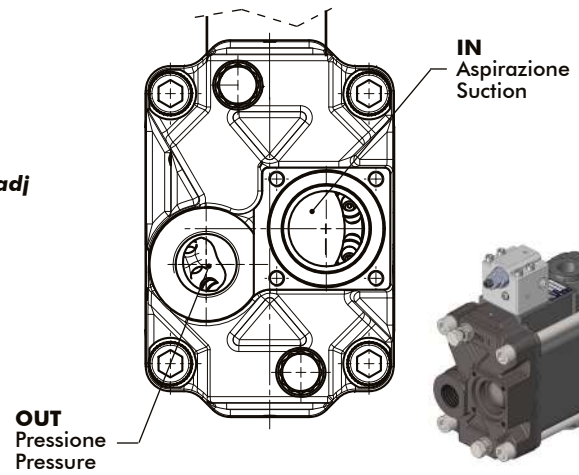

| AX | VERSIONE ASSIALE AXIAL VERSION | FFFST 1 BDDRRX | FFFST 5 BDDRRX |
|-----|---|----------------|-----------------|
| OUT | PRESSIONE PRESSURE | G 1 | 1 5/16-12 UN-2B |
| IN | ASPIRAZIONE / SUCTION Raccordo da ordinare separatamente Suction fitting to be ordered separately | Ø50mm | |

14/10/2021

99765011110 Rev: AP

FFFST 2 DDDR 1

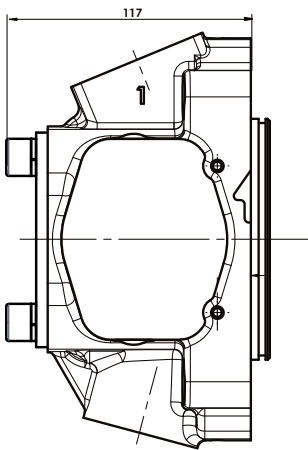

**ROTAZIONE DESTRA
RIGHT ROTATION**

Senza albero passante.
Con coperchio incluso.
Without thru-shaft.
With cover included.

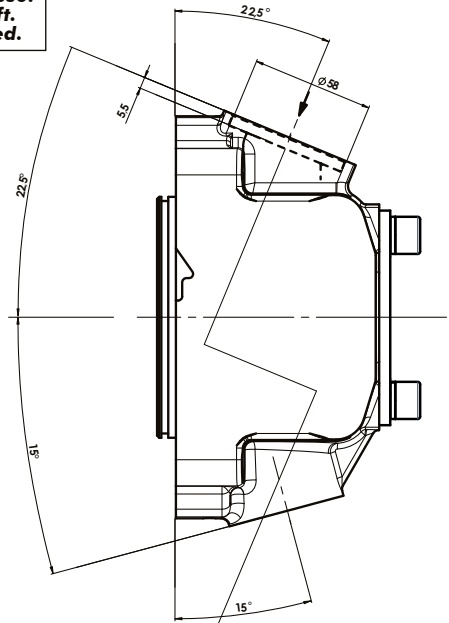
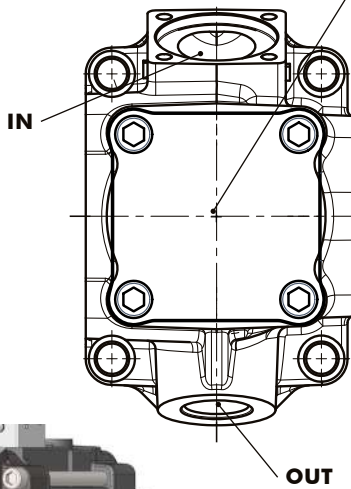

DX



| RV | VERSIONE RADIALE VERTICALE SENZA ALBERO PASSANTE VERTICAL RADIAL VERSION WITHOUT THRU-SHAFT | FFFS1 BDDR X | FFFS5 BDDR X |
|------------|--|---------------------|---------------------|
| OUT | PRESSIONE / PRESSURE | G 1 | 1 5/16-12 UN-2B |
| IN | ASPIRAZIONE / SUCTION Raccordo da ordinare separatamente Suction fitting to be ordered separately | Ø50mm | |

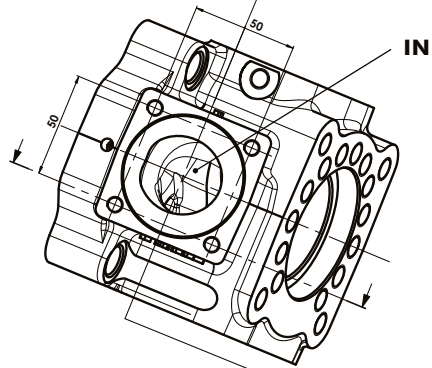

SX

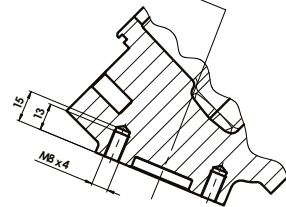

FFFST 2 DDDR 6

**ROTAZIONE SINISTRA
LEFT ROTATION**

Senza albero passante.
Con coperchio incluso.
Without thru-shaft.
With cover included.

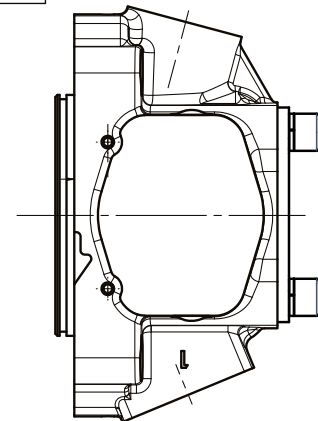
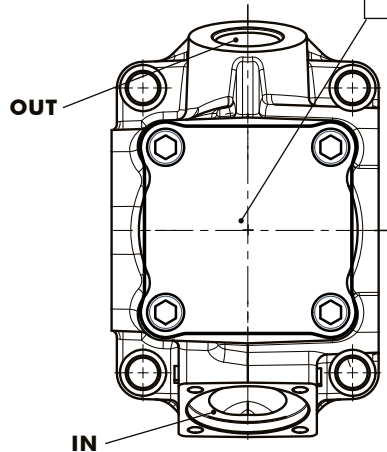
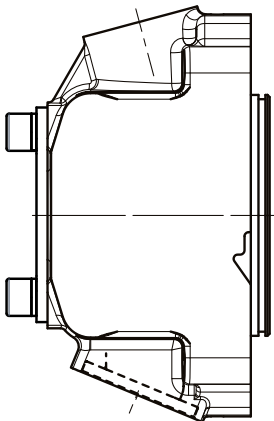

FFFST 3 DDDR 1

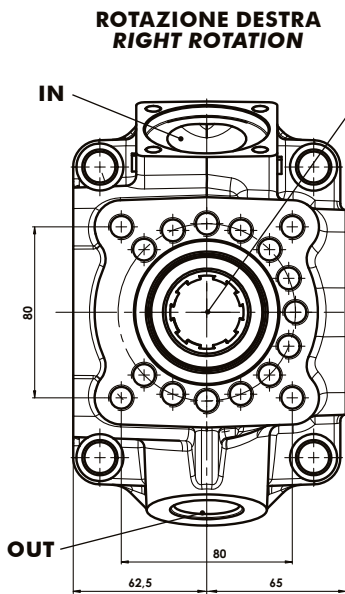
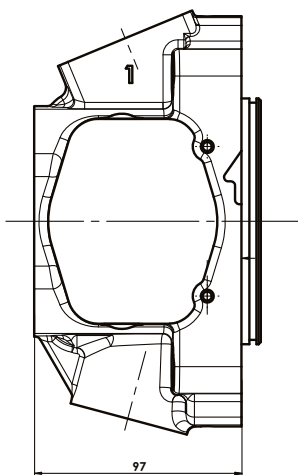

Con albero passante.
Senza coperchio.
With thru-shaft.
Cover not included.

Albero/Shaft
8x32x36
(ISO 14)

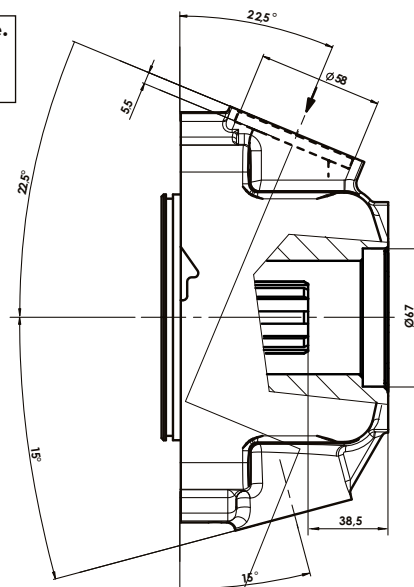

TANDEM DX

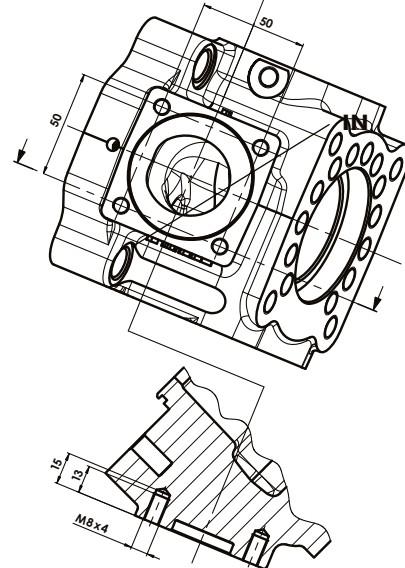

| PV | VERSIONE RADIALE VERTICALE CON ALBERO PASSANTE VERTICAL RADIAL VERSION WITH THRU-SHAFT | FFFS1 BDDRRX | FFFS5 BDDRRX |
|----|---|----------------------|--------------|
| | OUT | PRESSIONE / PRESSURE | G 1 |
| IN | ASPIRAZIONE / SUCTION Raccordo da ordinare separatamente Suction fitting to be ordered separately | Ø50mm | |

TANDEM SX



FFFST 3 DDDR 6

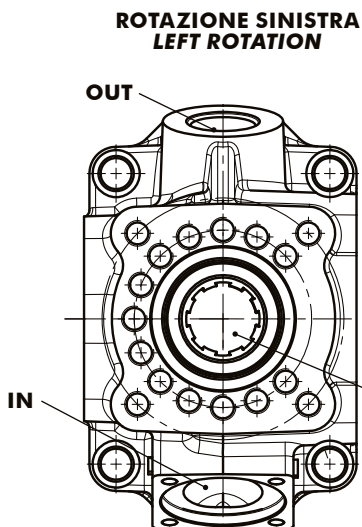
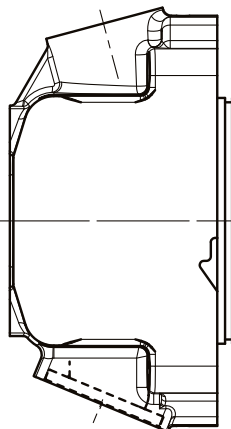

ROTAZIONE SINISTRA
LEFT ROTATION

Con albero passante.
Senza coperchio.
With thru-shaft.
Cover not included.

Albero/Shaft
8x32x36
(ISO 14)

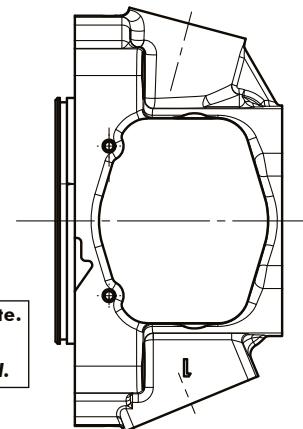

14/10/2021

99765011110 Rev: AP

FFFST 4 DDDR 1

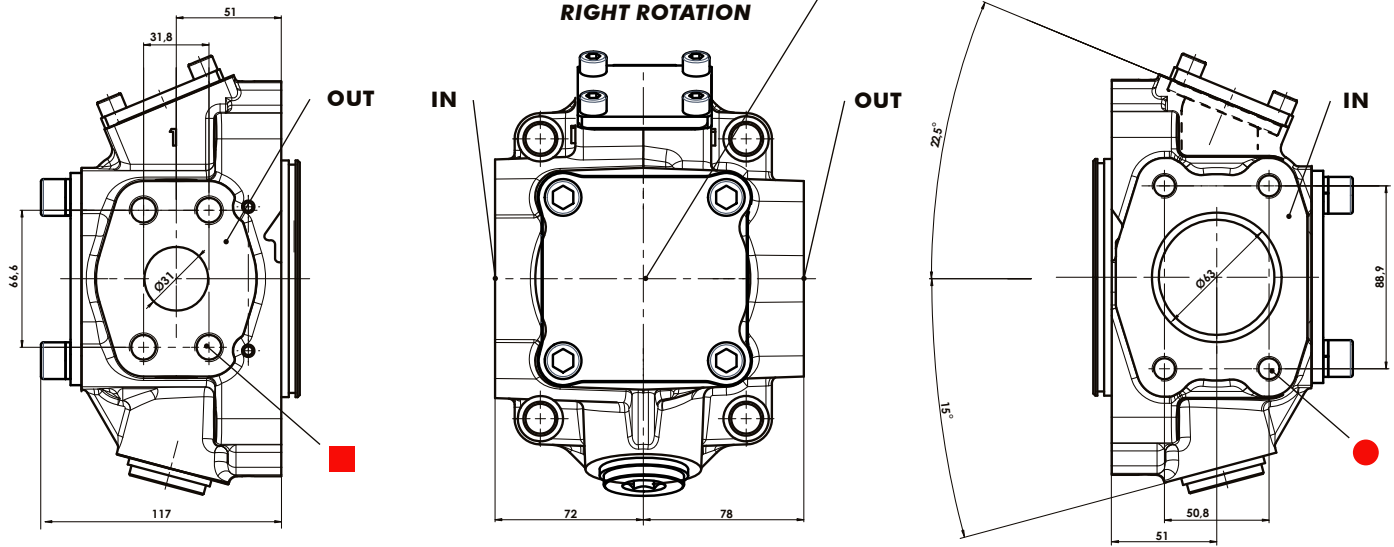

| RO | | VERSIONE RADIALE ORIZZONTALE SAE SENZA ALBERO PASSANTE HORIZONTAL RADIAL SAE VERSION WITHOUT THRU-SHAFT | | FFFS1BDDRRX | FFFS5BDDRRX |
|-----|------------------------|--|-------|-------------|-------------|
| OUT | PRESSIONE PRESSURE | 1 1/4" SAE 6000 | ■ M14 | ■ 1/2"UN | |
| IN | ASPIRAZIONE SUCTION | 2 1/2" SAE 3000 | ● M12 | ● 1/2"UN | |

DX



FFFST 4 DDDR 6

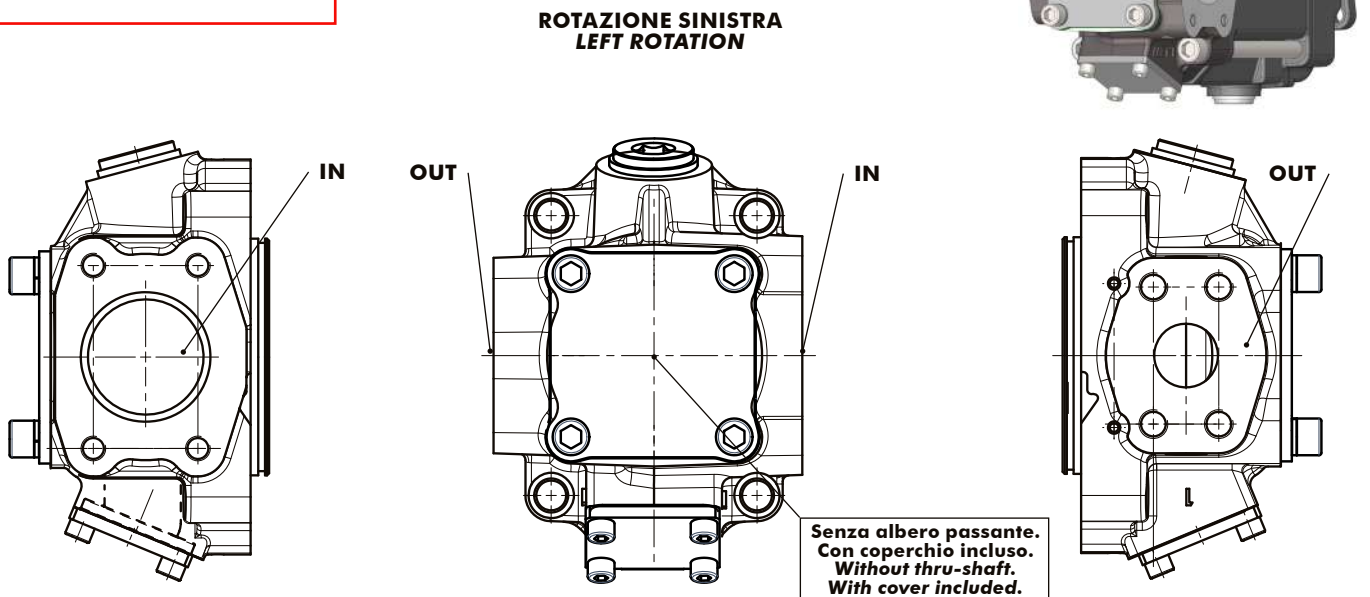

SX



FFFST 5 DDDR 1

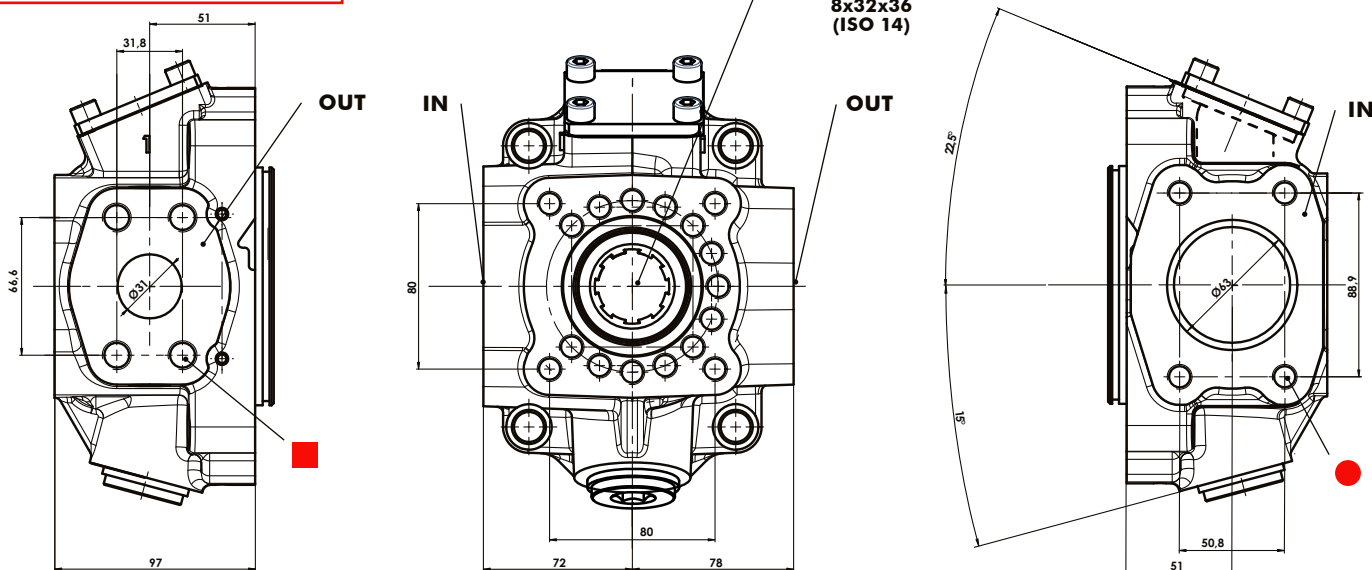

**ROTAZIONE DESTRA
RIGHT ROTATION**

| PO | | | VERSIONE RADIALE ORIZZONTALE SAE CON ALBERO PASSANTE HORIZONTAL RADIAL SAE VERSION WITH THRU-SHAFT | |
|------------|------------------------|-----------------|---|---------------|
| | | | FFFS 1 BDDRRX | FFFS 5 BDDRRX |
| OUT | PRESSIONE PRESSURE | 1 1/4" SAE 6000 | ■ M14 | ■ 1/2"UNC |
| IN | ASPIRAZIONE SUCTION | 2 1/2" SAE 3000 | ● M12 | ● 1/2"UNC |

**TANDEM
DX**



**TANDEM
SX**

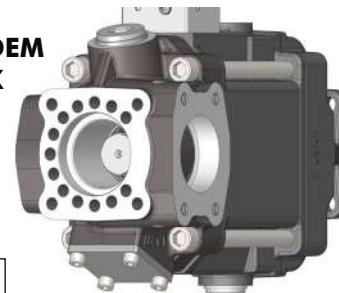

FFFST 5 DDDR 6

**ROTAZIONE SINISTRA
LEFT ROTATION**

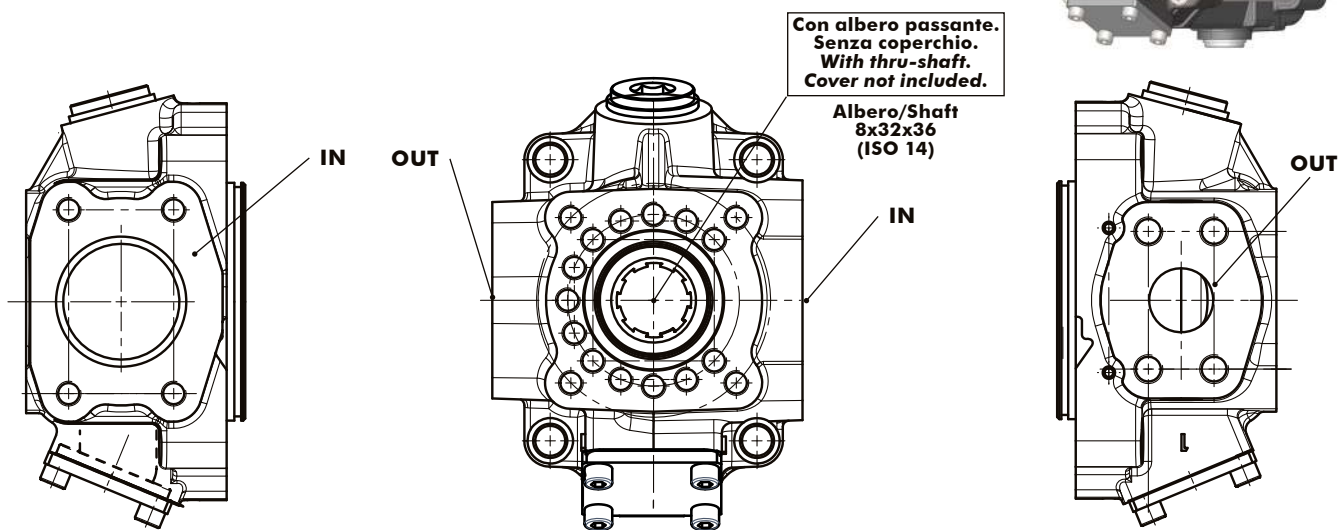

14/10/2021

99765011110 Rev: AP

POMPE A CILINDRATA VARIABILE VARIABLE DISPLACEMENT PUMPS

PPV 130 ADJUSTABLE

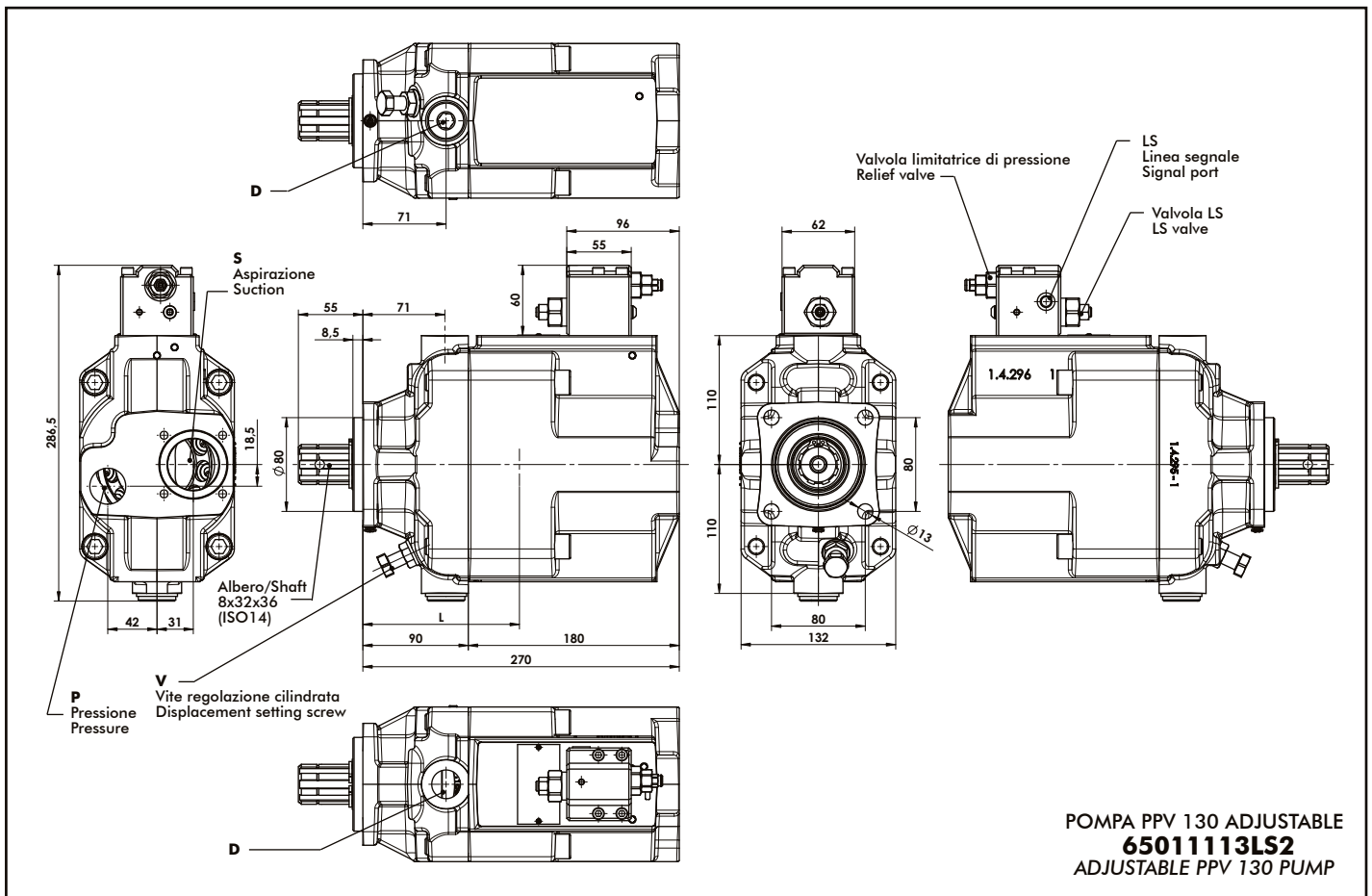

POMPA PPV 130 ADJUSTABLE
65011113LS2
ADJUSTABLE PPV 130 PUMP

FFFS1BDDRRX

| | | |
|------------|---|---------------------|
| LS | BLOCCHETTO LS/ LS BLOCK | G 1/4 |
| D | DRENAGGIO / DRAIN | G 3/4 |
| OUT | PRESSIONE / PRESSURE | G 1 |
| IN | ASPIRAZIONE / SUCTION Raccordo da ordinare separatamente Suction fitting to be ordered separately | $\varnothing 50$ mm |
| L | BARICENTRO / CENTER OF MASS | 145 mm circa/approx |

Regolatore PI / PI Control
vedi pagina/see page 30

pag.25

OMFB
HYDRAULIC COMPONENTS

O.M.F.B. S.p.a. Hydraulic Components
We reserve the right to make any changes without notice.
Edition 2016.08 No reproduction, however partial, is permitted.
Via Cave, 7/9 25050 Provaglio d'Iseo (Brescia) Italy Tel.: +39.030.9830611
Fax: +39.030.9839207-208 Internet:www.omfb.it e-mail:contatti@omfb.it

COMPANY WITH
QUALITY SYSTEM
CERTIFIED BY DNV GL
= ISO 9001:2015 =

6501TBDDRX

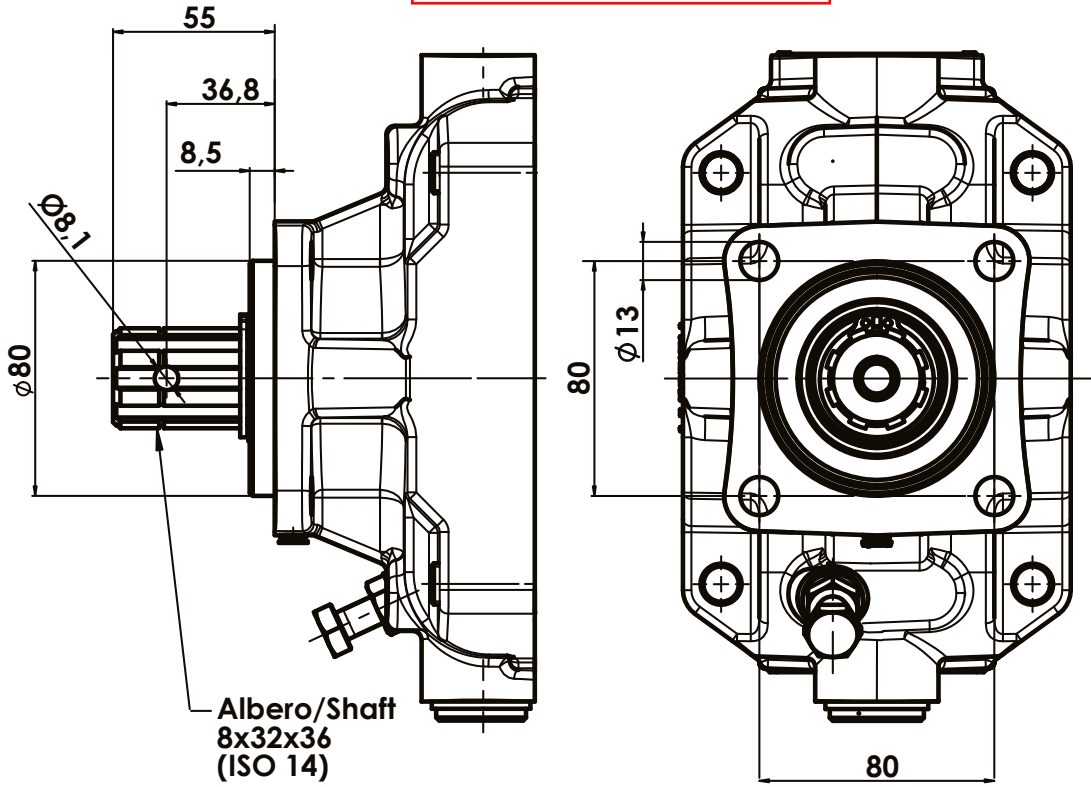

Albero/Shaft
8x32x36
(ISO 14)

COPPIA TRASMISSIBILE
MASSIMA 900Nm
MAX. TORQUE 900Nm

FFFST 1 DDDR 2

Rotazione destra/Right rotation
Senza limitazione/No adjustment

FFFST 1 DDDR 7

Rotazione sinistra/Left rotation
Senza limitazione/No adjustment

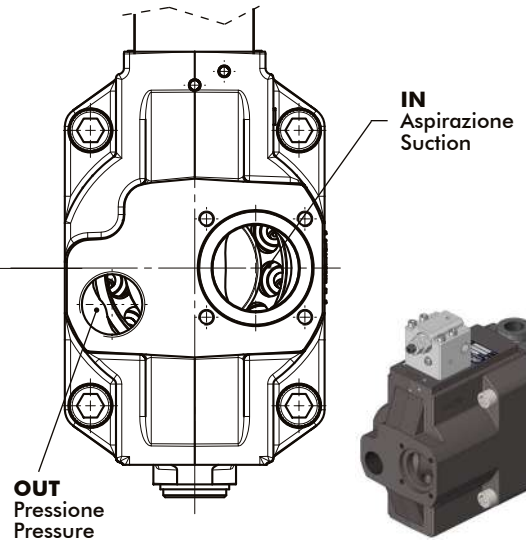
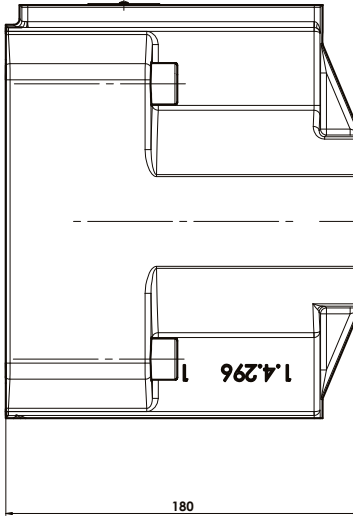
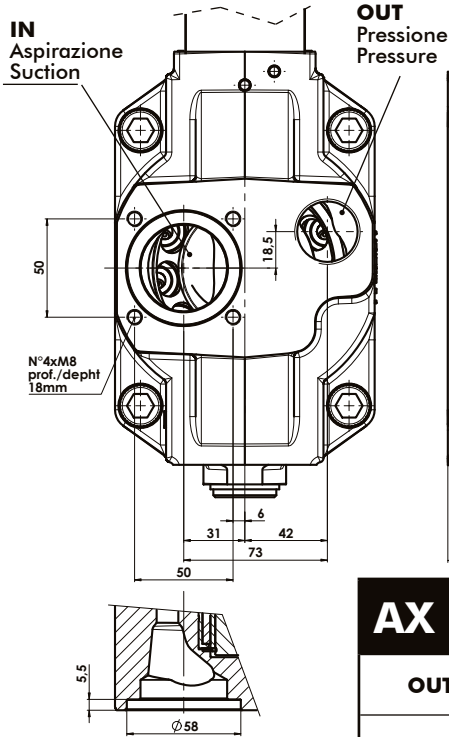

| AX | VERSIONE ASSIALE AXIAL VERSION | FFFST 1 BDDRRX |
|-----|---|----------------|
| OUT | PRESSIONE PRESSURE | G 1 |
| IN | ASPIRAZIONE / SUCTION Raccordo da ordinare separatamente Suction fitting to be ordered separately | Ø50mm |

REGOLATORI CONTROLS

FFFSTBDDL**LSX**

REGOLATORE LOAD SENSING LS

Regolare la pressione differenziale Δp = pressione impianto meno pressione segnale.
L'intervallo di regolazione è 15-50 bar.
Settaggio preimpostato 25 bar \pm 2%.
Regolazione 15 bar/rev.

Regolare la pressione max. dell'impianto fra 20 e 350 bar.
Il valore preimpostato della valvola limitatrice di pressione è di 330 bar.
Regolazione 150 bar/rev.

La capacità della linea di segnale LS deve adattarsi al relativo impianto idraulico. La linea di segnale deve essere preferibilmente costituita da un tubo flessibile di diametro idoneo a garantire lo smorzamento di eventuali fluttuazioni del segnale LS.

LS LOADING SENSING CONTROL

Regulate the differential pressure Δp = circuit pressure less signal pressure.
The adjustment range is 15-50 bar.
Default setting 25 bar \pm 2%.
Setting 15 bar/rev.

Adjust the maximum pressure of hydraulic circuit between 20 and 350 bar.
The default setting of the pressure relief valve is 330 bar.
Setting 150 bar/rev.

The capacity of the LS line has to be adapted to the related hydraulic circuit. The signal line should preferably consist of a flexible hose having suitable diameter to ensure the damping of possible LS signal fluctuations.

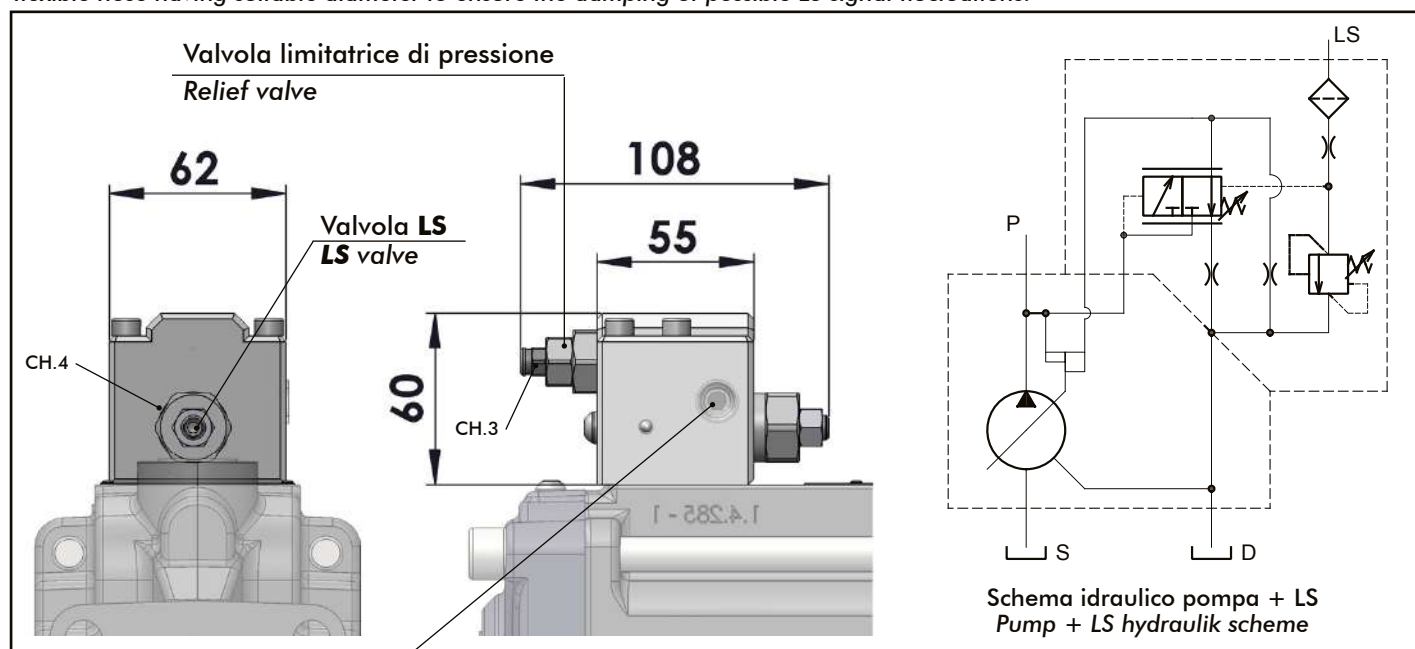

LS
Linea segnale
Signal port

FFF1BDDLSX****
Filettatura/Thread G1/4

FFF5BDDLSX****
Filettatura/Thread G1/4

7/16-20-04JIC

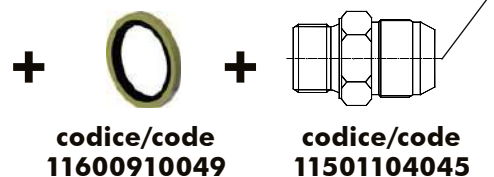

codice/code
11600910049

codice/code
11501104045

14/10/2021

99765011110 Rev: AP

FFFSTBDDPIX

REGOLATORE PI

Regolare la pressione minima = pressione impianto meno pressione segnale.
 L'intervallo di regolazione è 15-50 bar.
 Settaggio preimpostato 25 bar ±2%.
 Regolazione 15 bar/rev.

 Regolare la pressione max. dell'impianto fra 20 e 350 bar.
 Il valore preimpostato della valvola limitatrice di pressione è di 330 bar.
 Regolazione 150 bar/rev.

Regolatore di pressione con pressione impostabile sulla valvola.
 Questo regolatore mantiene una pressione costante nel circuito idraulico al variare della portata.
 Il controllo modula la portata della pompa in modo idoneo a mantenere la pressione del sistema al valore impostato sulla valvola di massima. È quindi concepito per sistemi a pressione costante nei quali occorrono diverse portate o come limitazione della pressione a bassa perdita di un sistema idraulico.

PI CONTROL

Regulate the minimum pressure = circuit pressure less signal pressure.
 The adjustment range is 15-50 bar.
 Default setting 25 bar ±2%.
 Setting 15 bar/rev.

 Adjust the maximum pressure of hydraulic circuit between 20 and 350 bar.
 The default setting of the pressure relief valve is 330 bar.
 Setting 150 bar/rev.

Adjustable Pressure control.
 This control ensures a constant pressure in the hydraulic circuit by changing the flow.
 The control adjusts the flow in such a way to keep constantly the pressure value set at the relief valve.
 It is therefore designed for applications with constant pressure where different flow rates are required or as a limitation of low pressure drop within a hydraulic system.

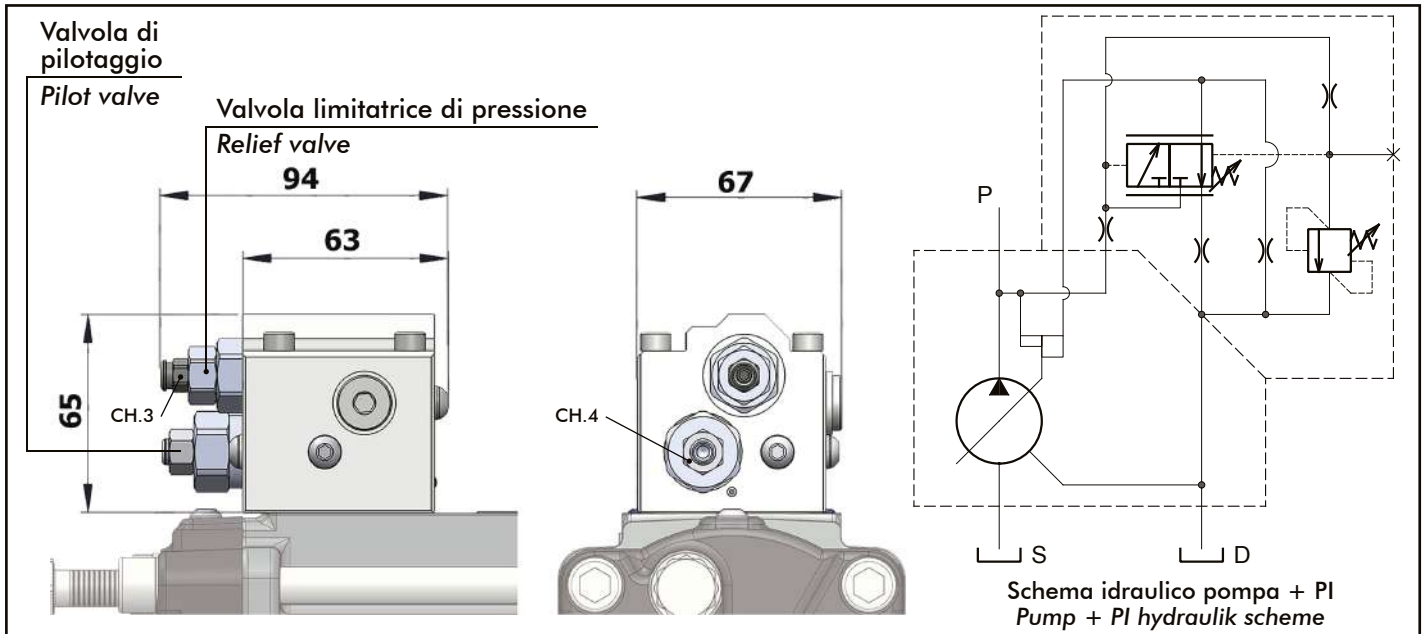

14/10/2021

99765011110 Rev: AP

FFFSTBDDPEX

**DISPONIBILE A BREVE
COMING SOON**

REGOLATORE PE

Regolare la pressione minima = pressione impianto meno pressione segnale.
L'intervallo di regolazione è 15-50 bar.
Settaggio preimpostato 25 bar ±2%.
Regolazione 15 bar/rev.

Regolare la pressione max. dell'impianto fra 20 e 350 bar.
Il valore preimpostato della valvola limitatrice di pressione è di 330 bar.
Regolazione 150 bar/rev.

Regolatore di pressione con pressione massima e minima impostabili sulle valvole ed intermedia impostabile elettricamente. Questo regolatore mantiene una pressione costante nel circuito idraulico al variare della portata. Il controllo modula la portata della pompa in modo idoneo a mantenere la pressione del sistema al valore impostato sulla valvola di massima. È quindi concepito per sistemi a pressione costante nei quali occorrono diverse portate: le pressioni massima e minima sono impostabili in modo meccanico, la pressione nel mezzo è regolabile elettricamente. La curva del regolatore ha caratteristica crescente.

PE CONTROL

Regulate the minimum pressure = circuit pressure less signal pressure.
The adjustment range is 15-50 bar.
Default setting 25 bar ±2%.
Setting 15 bar/rev.

Adjust the maximum pressure of hydraulic circuit between 20 and 350 bar.
The default setting of the pressure relief valve is 330 bar.
Setting 150 bar/rev.

Pressure regulator with minimum and maximum pressure rates adjustable on the valves and with electrically adjustable intermittent pressure. This control ensures a constant pressure in the hydraulic circuit by changing the flow. It is therefore designed for applications with constant pressure where different flow rates are required: minimum and maximum pressure rates are set mechanically while intermediate pressure is electrically controlled.

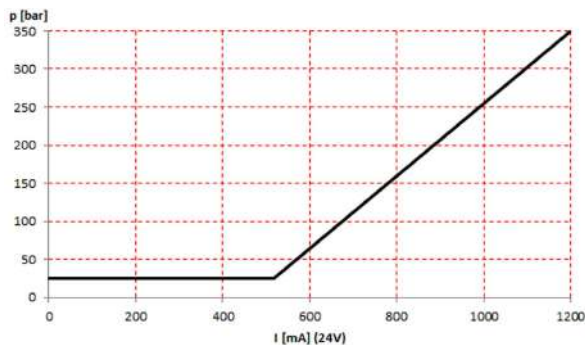
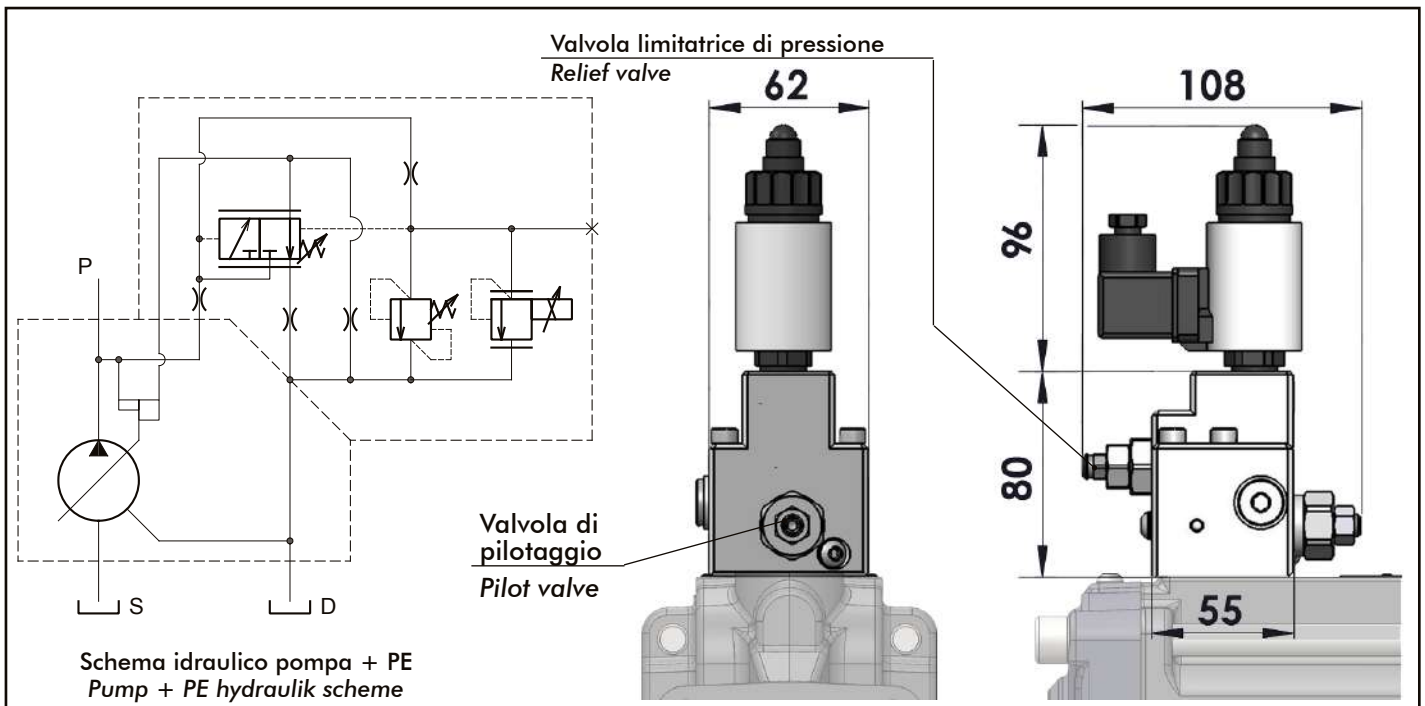

14/10/2021

99765011110 Rev: AP

FFFSTBDDPWX

**DISPONIBILE A BREVE
COMING SOON**

REGOLATORE PW (potenza costante)

Regolatore di potenza massima assorbita con un campo di regolazione di coppia tra i 200 e i 700 Nm. Questo regolatore adatta la cilindrata della pompa in funzione della pressione nell'impianto, in modo che la coppia assorbita non superi il valore impostato in modo che l'albero motore, il motore o la trasmissione siano protetti da sovraccarichi.

PW CONTROL

Maximum absorbed power regulator with a torque adjustment range between 200 and 700 Nm. The regulator adapts the pump displacement according to the pressure in the system, to maintain the pre-adjusted torque value and protect motor shaft, motor or transmission from overloads.

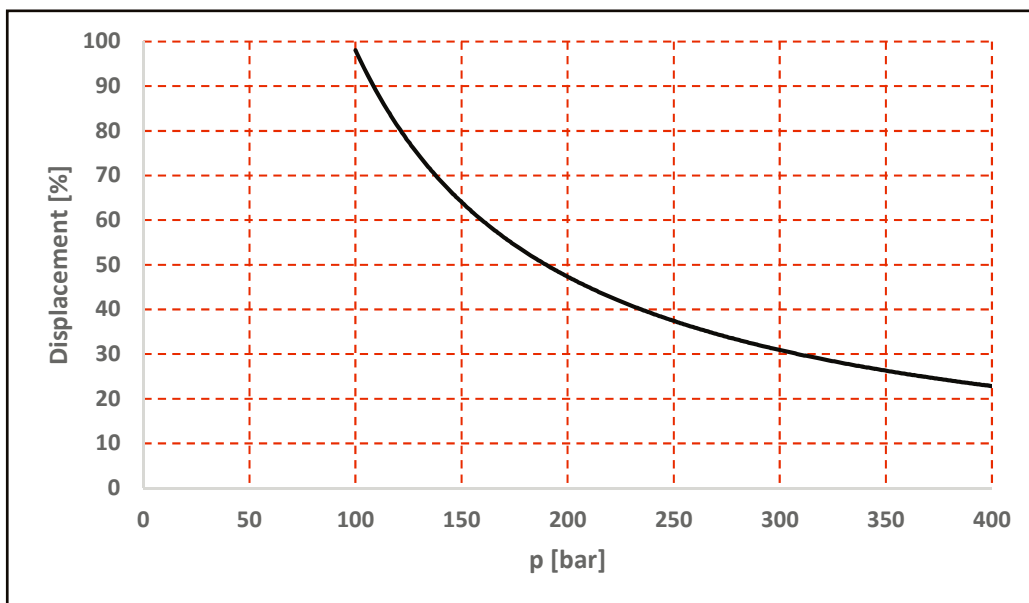
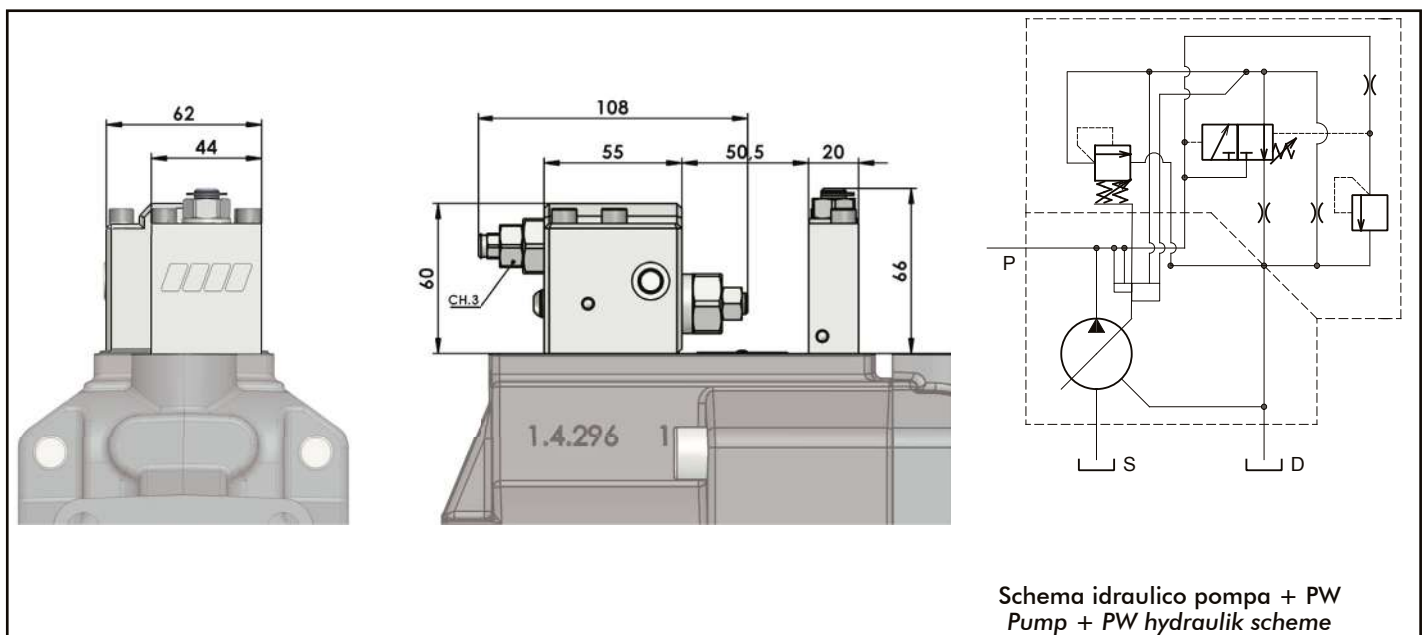

14/10/2021

99765011110 Rev: AP

Valvola di flussaggio per circuiti load sensing Flushing valve for load sensing circuit

La valvola garantisce una minima circolazione di olio verso scambiatore di calore o serbatoio per proteggere la pompa da surriscaldamento negli impianti in cui la pompa lavora molto tempo in azzeramento di cilindrata (condizione di stand-by). Durante il funzionamento con distributore o blocchi, la valvola viene esclusa automaticamente con comando idraulico o attraverso un comando elettrico la cui logica di controllo è a carico del cliente.

The valve guarantees small flow through the pump to cooling or tank, in order to protect the pump from overheated on the application with long time in stand-by condition. When a load sensing valve function is engaged the flushing valve is disengaged automatically with hydraulic pilot or with electrical pilot by the logic control of customer.

Caratteristiche tecniche:

Portata libera circolazione: 30 l/min
Pressione di regolazione: da 2 a 25 bar
Pressione massima: 420 bar
Porte: G1/4

Technical characteristics:

Flow control: 30 l/min
Pilot pressure settings: da 2 a 25 bar
Maximum pressure: 420 bar
Ports: G1/4

| Comando idraulico / Hydraulic pilot | | Comando elettrico / Electrical pilot | |
|-------------------------------------|--|--------------------------------------|-------------------|
| Codice / Code | | Codice / Code | |
| B5001072001BC | | B5001072002BC | 24V DIN |
| | | B5001072003BC | 12V DIN |
| | | B5001072004BC | 24V DEUTCH |
| | | B5001072005BC | 12V DEUTCH |
| | | | |
| | | | |

14/10/2021

99765011110 Rev: AP

REGOLATORE A PORTATA COSTANTE (CF) CONSTANT FLOW CONTROL (CF)

Il regolatore a portata costante garantisce una portata fissa al variare della velocità e del carico sulla pompa, grazie al compensatore load sensing. Il regolatore mantiene costante la differenza di pressione tra monte e valle dello strozzatore sulla linea P. La taratura del regolatore è variabile tra i 15 e 40 bar.

The constant flow control guarantee a fixed flow rate at different pump speed and load. The regulator keeps the pressure margin across the orifice into P line. Setting of pressure margin: 15 to 40 bar.

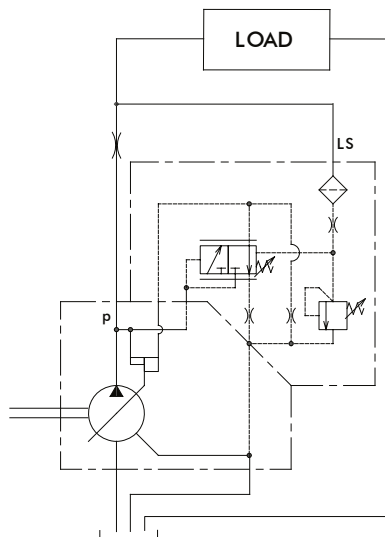

| | |
|------------------|------|
| PPV60 | G3/4 |
| PPV90 110-130 | G1 |

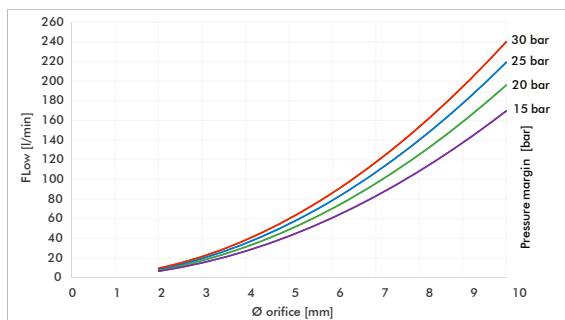
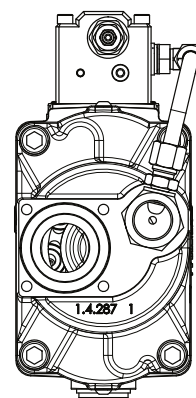
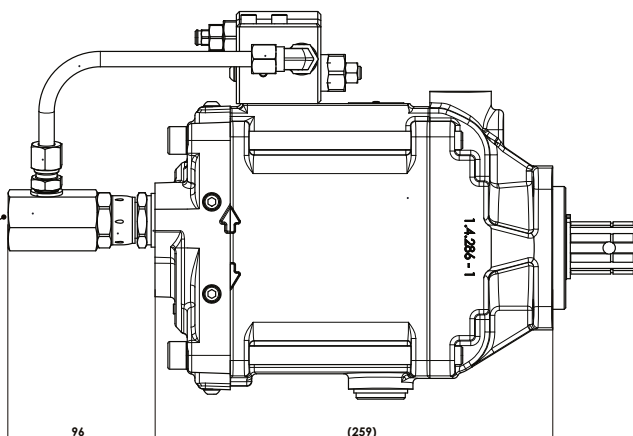

Il regolatore a portata costante è disponibile con diverse tarature di portata, per ogni ulteriore informazioni si prega di contattare il servizio tecnico.
The constant flow regulator is available with different flow settings, for any further information please contact the technical service.

APPLICAZIONI PPV TANDEM TANDEM PPV APPLICATIONS

Versione flange ed alberi (lato uscita) - Flange and shaft version (output side)

| Codice/Code | PPV60 | PPV90 PPV110 | Descrizione Description | Flangia/Flange | Albero/Shaft | Coppia max. trasmissibile Max. output torque |
|-------------|-------------|-----------------|------------------------------|---|--|---|
| | | | | | | T _{OUT} max. |
| 1 | 1140000839 | | Solo coperchio Only cover | --- | --- | --- |
| 2 | 11465000066 | | ISO | DIN ISO 7653 | 8x32x36 DIN ISO 14 | 800 Nm |
| 3 | 11465000100 | | ISO | DIN ISO 7653 | 8x32x36 DIN ISO 14 | |
| 4 | 11465010064 | | SAE A | SAE A 2-hole J744 82-2 DIN ISO 3019-1 | SAE A J744 (16-4 DIN ISO 3019-1) 9T 16/32 DP | 100 Nm |
| 5 | 11465010108 | | SAE A | SAE A 2-hole J744 82-2 DIN ISO 3019-1 | SAE A J744 (16-4 DIN ISO 3019-1) 9T 16/32 DP | |
| 6 | 11465010162 | | SAE B | SAE B 2-hole J744 101-2 DIN ISO 3019-1 | SAE B J744 (22-4 DIN ISO 3019-1) 13T 16/32 DP | 210 Nm |
| | | | | SAE B 4-hole J744 101-4 DIN ISO 3019-1 Ruotata di 20° / 20° rotation | | |
| 7 | 11465010206 | | SAE B | SAE B 2-hole J744 101-2 DIN ISO 3019-1 | SAE B J744 (22-4 DIN ISO 3019-1) 13T 16/32 DP | |
| | | | | SAE B 4-hole J744 101-4 DIN ISO 3019-1 Ruotata di 20° / 20° rotation | | |
| 8 | 11465010304 | | SAE BB | SAE B 2-hole J744 101-2 DIN ISO 3019-1 | SAE BB J744 (25-4 DIN ISO 3019-1) 15T 16/32 DP | 400 Nm |
| | | | | SAE B 4-hole J744 101-4 DIN ISO 3019-1 Ruotata di 20° / 20° rotation | | |
| 9 | 11465010402 | | SAE C | SAE C 2-hole J 744 127-2 DIN ISO 3019-1 | SAE C J744 (32-4 DIN ISO 3019-1) 14T 12/24 DP | 640 Nm |
| | | | | SAE C 4-hole J 744 127-4 DIN ISO 3019-1 | | |
| 10 | 11465030104 | | European | GR.3 "EUROPEAN" | 35x31 DIN 5482 | 240 Nm |

Prestare attenzione alla coppia massima trasmissibile: se non rispettata, la flangia o l'albero potrebbero venire danneggiati.
Un supporto addizionale sarebbe opportuno per più pompe combinate.
Possibilità di avere versioni aggiuntive a richiesta.

Pay attention to the maximum permissible drive torque: flange or shaft may be damage.
An additional support is to be provided for pump combinations.
Additional version on request.

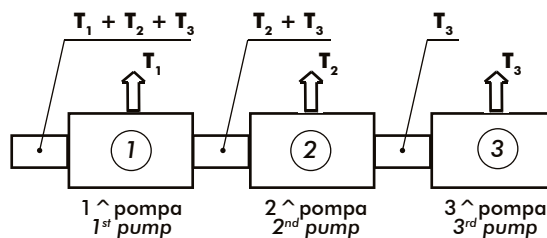
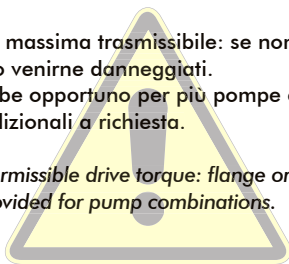

Coppia 1[^] pump T₁
Coppia 2[^] pump T₂
Coppia 3[^] pump T₃

Coppia in ingresso T_{IN} = T₁ + T₂ + T₃
T_{IN} < 900Nm for 6501TBDDRRX
T_{IN} < 640Nm for 6512TBDDRRX

Coppia in uscita T_{OUT} = T₂ + T₃
T_{OUT, 1} = T₂ + T₃
T_{OUT, 1} < T_{OUT, MAX}..... vedere tabella

T_{OUT, 2} = T₃
T_{OUT, 2} < T_{OUT, MAX}..... vedere tabella

Torque at 1st pump T₁
Torque at 2nd pump T₂
Torque at 3rd pump T₃

Input torque T_{IN} = T₁ + T₂ + T₃
T_{IN} < 900Nm for 6501TBDDRRX
T_{IN} < 640Nm for 6512TBDDRRX

Output torque T_{OUT} = T₂ + T₃
T_{OUT, 1} = T₂ + T₃
T_{OUT, 1} < T_{OUT, MAX}..... see table

T_{OUT, 2} = T₃
T_{OUT, 2} < T_{OUT, MAX}..... see table

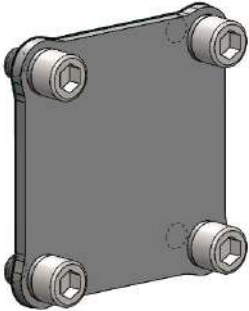
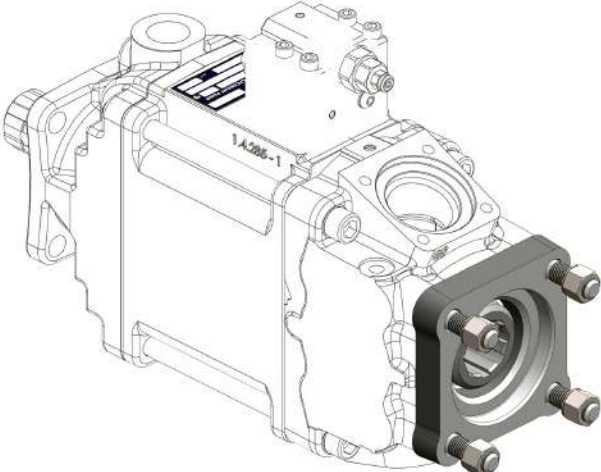
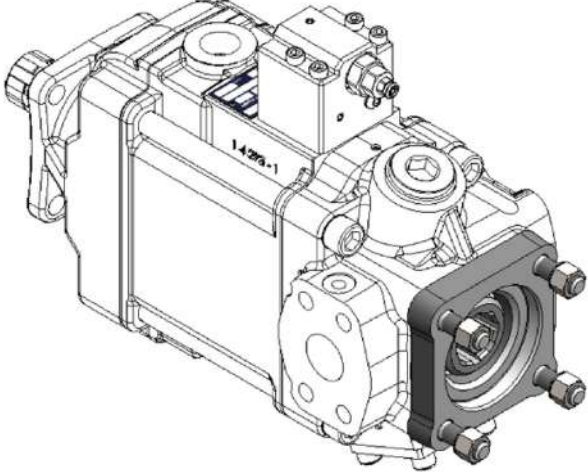
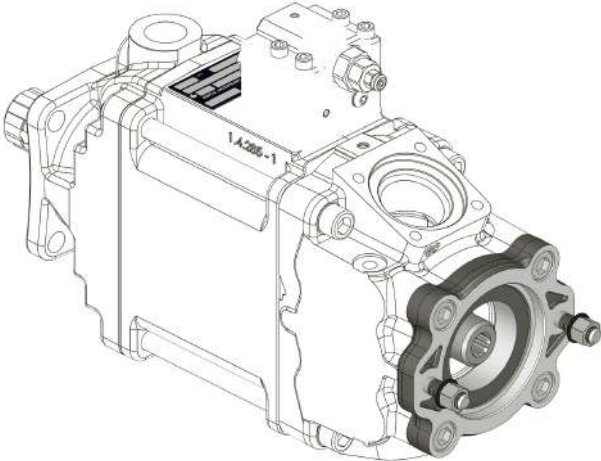
| | | |
|-----------------|---|--|
| <p>1</p> |  | <p>1140000839</p> <p>COPERCHIO DI CHIUSURA</p> <p>COVER</p> |
| <p>2</p> |  | <p>1146500066</p> <p>APPLICAZIONE PPV60 TANDEM / POMPA ISO 7653 (coppia trasmissibile 800Nm)</p> <p>PPV 60 TANDEM / ISO 7653 PUMP ADAPTOR (Max. allowed torque 800Nm)</p> |
| <p>3</p> |  | <p>11465000100</p> <p>APPLICAZIONE PPV TANDEM MEDIE / POMPA ISO 7653 (coppia trasmissibile 800Nm)</p> <p>PPV TANDEM MEDIUM SIZE / ISO 7653 PUMP ADAPTOR (Max. allowed torque 800Nm)</p> |
| <p>4</p> |  | <p>11465010064</p> <p>APPLICAZIONE PPV60 TANDEM / POMPA SAE A Z9 (coppia trasmissibile 100Nm)</p> <p>PPV 60 TANDEM / SAE A Z9 PUMP ADAPTOR (Max. allowed torque 100Nm)</p> |

5

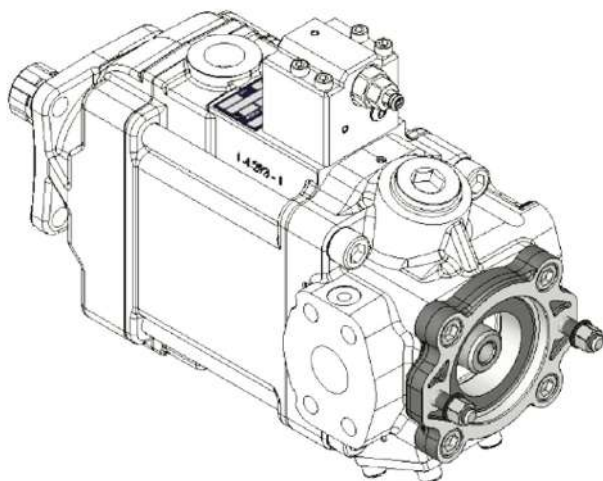

11465010108

APPLICAZIONE PPV TANDEM MEDIE
/
POMPA SAE A Z9
(coppia trasmissibile 100Nm)

PPV TANDEM MEDIUM SIZE
/
SAE A Z9 PUMP ADAPTOR
(Max. allowed torque 100Nm)

6

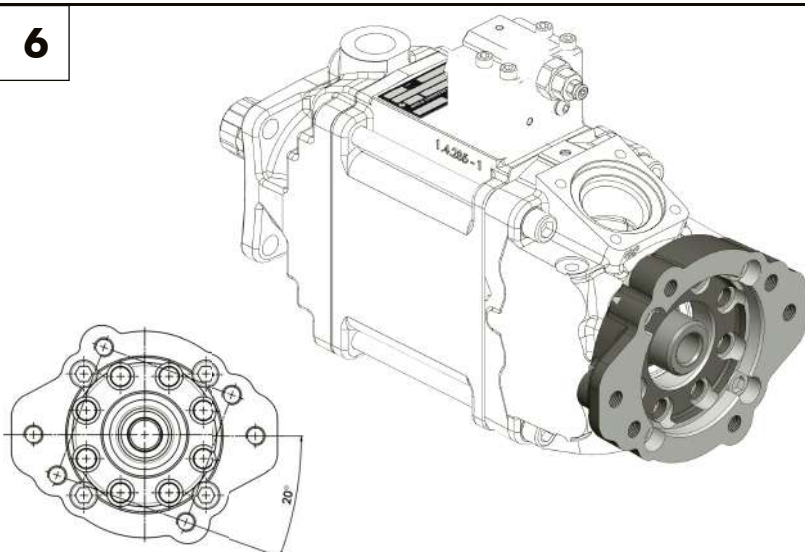

11465010162

APPLICAZIONE PPV60 TANDEM
/
POMPA SAE B Z13
(coppia trasmissibile 210Nm)

PPV 60 TANDEM
/
SAE B Z13 PUMP ADAPTOR
(Max. allowed torque 210Nm)

7

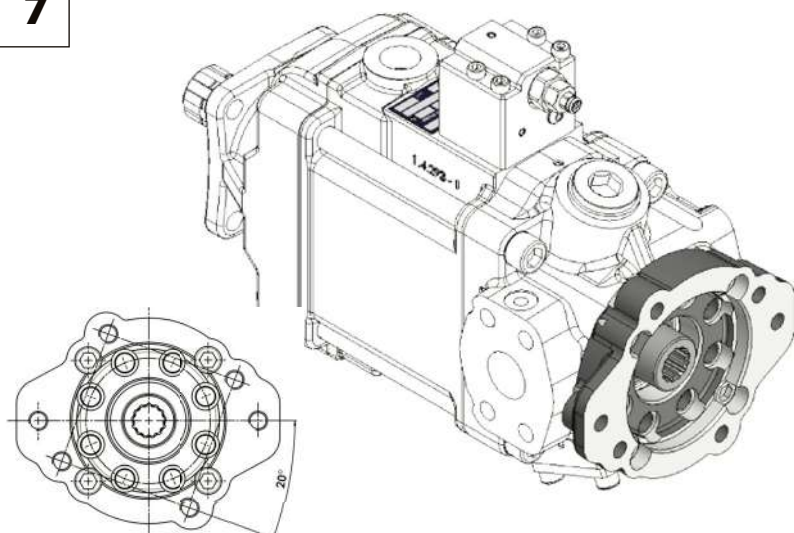

11465010206

APPLICAZIONE PPV TANDEM MEDIE
/
POMPA SAE B Z13
(coppia trasmissibile 210Nm)

PPV TANDEM MEDIUM SIZE
/
SAE B Z13 PUMP ADAPTOR
(Max. allowed torque 210Nm)

14/10/2021

99765011110 Rev: AP

8

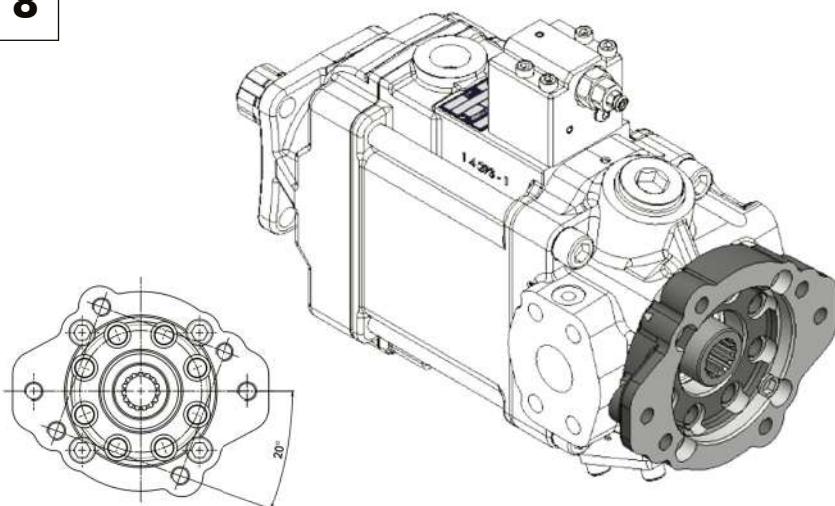

11465010304

APPLICAZIONE PPV TANDEM MEDIE
/
POMPA SAE BB Z15
(coppia trasmissibile 400Nm)

PPV TANDEM MEDIUM SIZE
/
SAE BB Z15 PUMP ADAPTOR
(Max. allowed torque 400Nm)

9

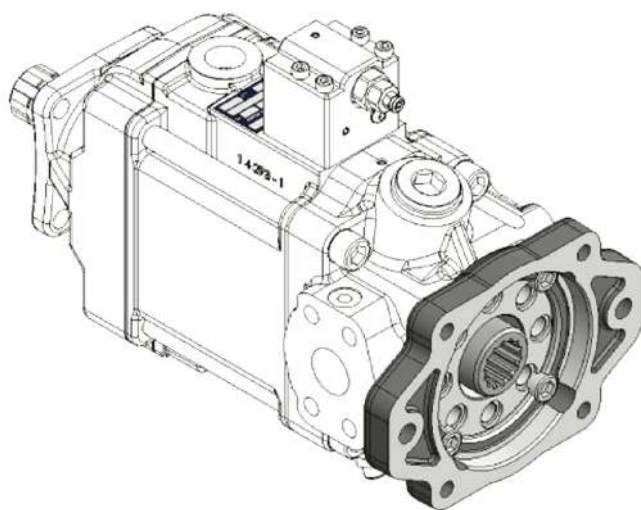

11465010402

APPLICAZIONE PPV TANDEM MEDIE
/
POMPA SAE C Z14
(coppia trasmissibile 640Nm)

PPV TANDEM MEDIUM SIZE
/
SAE C Z14 PUMP ADAPTOR
(Max. allowed torque 640Nm)

10

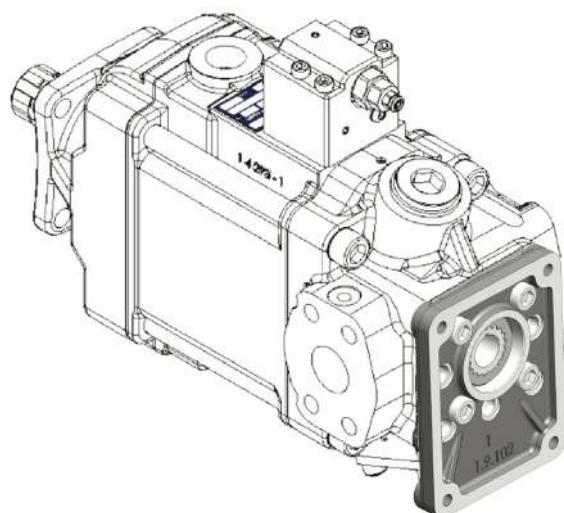

11465030104

APPLICAZIONE PPV TANDEM MEDIE
/
GR.3 "EUROPEAN"
(coppia trasmissibile XXXNm)

PPV TANDEM MEDIUM SIZE
/
GR.3 "EUROPEAN"
(Max. allowed torque XXXNm)

14/10/2021

99765011110 Rev: AP

RICAMBI E GUARNIZIONI GASKETS AND SPARE PARTS

**Kit guarnizioni
Gaskets kit 10895060028**

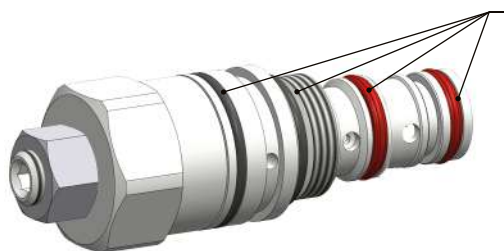

**Valvola LS
LS valve
10896090100**

**Kit guarnizioni
Gaskets kit 10895060037**

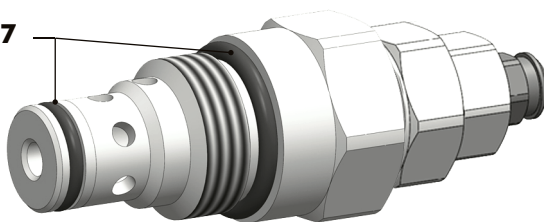

**Valvola limitatrice
di pressione
Relief valve
10896090208**

PPV 60-90-110

**Blocchetto LS - LS block
10896000108 - PPV 60
10896000117 - PPV 90-110**

50600019597

50600019588 (n°3)

50600024272

50600013137

**Kit guarnizioni completo
Gaskets kit assembly
10895060019**

50600012093 (PPV 60) (n°2)
50600012093 (PPV 90-110) (n°4)

50600011620 (PPV 60)
50600019551 (PPV 90-110)

50600011220 (PPV 60)

50600019579 (PPV 90-110)

50600019542 (n°2) - PPV 60
50600010106 (n°2) - PPV 90-110

**Kit guarnizioni pompa completo - Pump gaskets kit assembly
10895060608 (PPV 60) / 10895060751 (PPV 90-110)**

14/10/2021

99765011110 Rev: AP

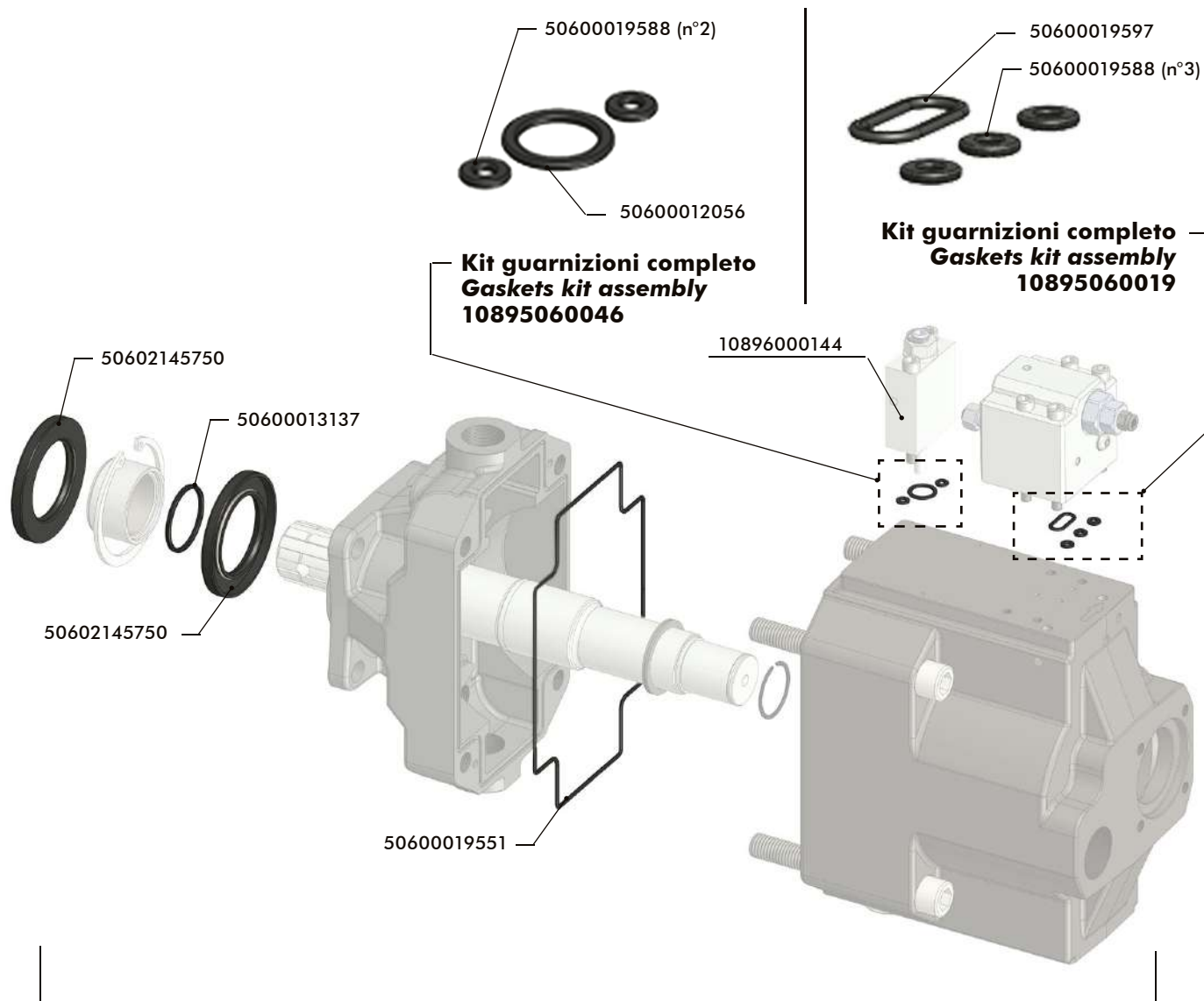

Kit guarnizioni pompa completo
Pump gaskets kit assembly
10895061303 (PPV 130)

Ricambi piatto distributore
Port plate spare parts

| Tipo pompa Pump type | | Kit ricambio piatto distributore Port plate spare part kit |
|-------------------------|----|---|
| PPV 60 | DX | 108-960-20604 |
| | SX | 108-960-10606 |
| PPV 90 | DX | 108-960-20908 |
| | SX | 108-960-10900 |
| PPV 110 | DX | 108-960-21103 |
| | SX | 108-960-11105 |

DX = Piastra di distribuzione rotazione destrorsa / Port plate for clockwise rotation
 SX = Piastra di distribuzione rotazione sinistrorsa / Port plate for counter rotation

ACCESSORI ACCESSORIES

RACCORDI ASPIRAZIONE SUCTION FITTINGS

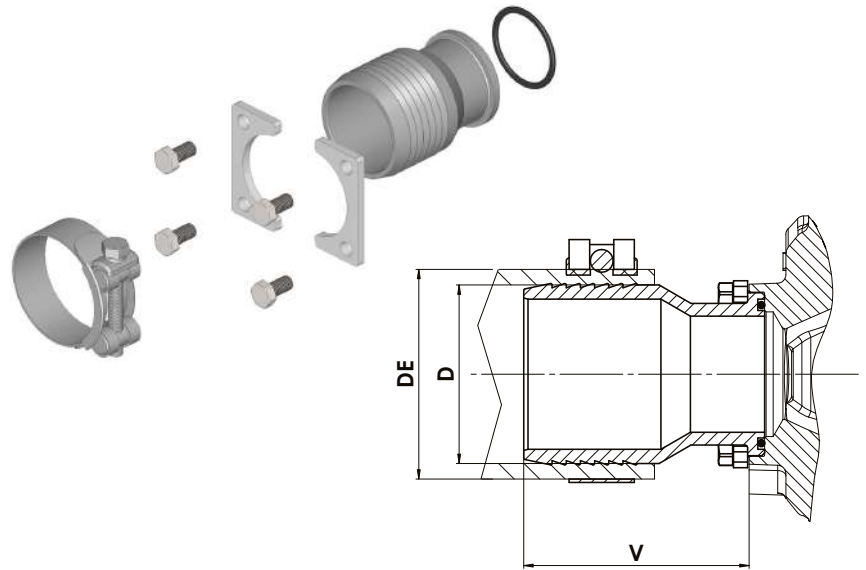

| Codice Code | D | DE | V | Peso Weighth |
|-------------|----|-------|----|--------------|
| | mm | mm | mm | Kg |
| 15511200507 | 50 | 60-63 | 59 | 0,59 |
| 15511200516 | 50 | 64-67 | 59 | 0,6 |
| 15511200605 | 60 | 68-73 | 79 | 0,77 |
| 15511200632 | 63 | 74-79 | 79 | 0,8 |
| 15511200767 | 76 | 86-91 | 94 | 1 |



45°

| Codice Code | D | DE | Z | Peso Weighth |
|-------------|----|-------|-----|--------------|
| | mm | mm | mm | Kg |
| 15511245504 | 50 | 60-63 | 141 | 1 |
| 15511245513 | | 64-67 | | |
| 15511245602 | 60 | 68-73 | 161 | 1,4 |
| 15511245639 | 63 | 74-79 | 163 | 1,7 |
| 15511245764 | 76 | 86-91 | 167 | 2,1 |

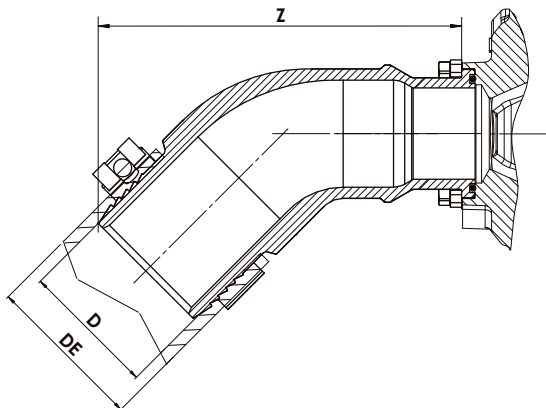

90°

| Codice Code | D | DE | V | Z | Peso Weighth |
|-------------|----|-------|-----|-----|--------------|
| | mm | mm | mm | mm | Kg |
| 15511290509 | 50 | 60-63 | 94 | 120 | 1,1 |
| 15511290518 | | 64-67 | | | |
| 15511290607 | 60 | 68-73 | 103 | 139 | 1,5 |
| 15511290634 | 63 | 74-79 | 103 | 139 | 1,9 |
| 15511290769 | 76 | 86-91 | 103 | 140 | 2,3 |

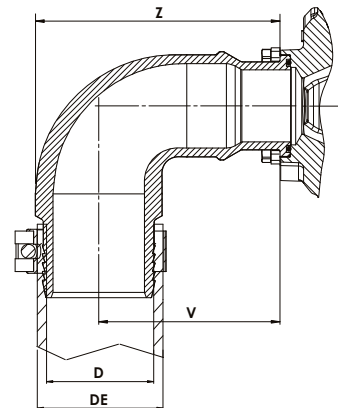

14/10/2021

99765011110 Rev: AP

15511300408

Kit flangia foro filettato G1-1/2, per montaggio raccordi GOLD.
 Flange kit G1-1/2 threaded hole, for mounting GOLD fittings.

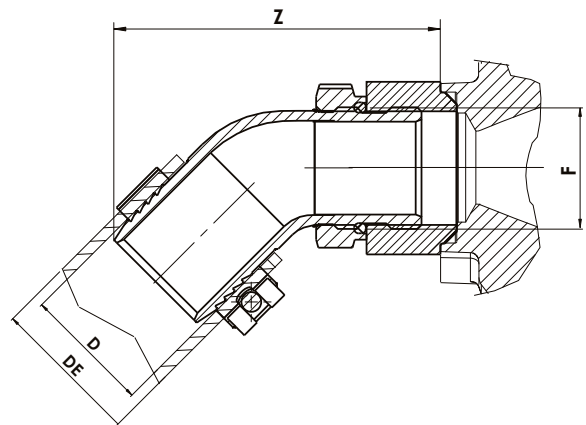
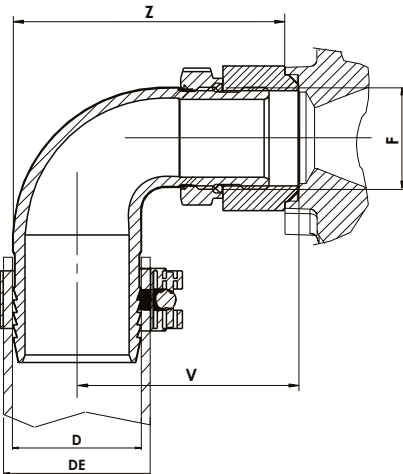
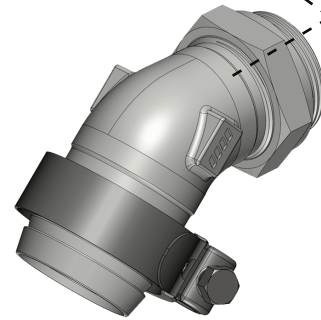
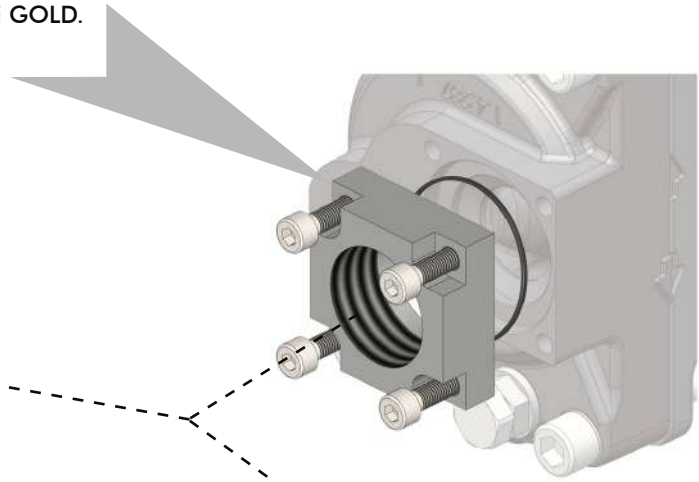

| Codice Code | F | D | DE | V | Z | Peso Weight |
|-------------|---------|----|-------|----|-----|-------------|
| | ISO 228 | mm | mm | mm | mm | Kg |
| 15510000592 | G1-1/2 | 50 | 60-63 | 85 | 114 | 0,99 |
| 15510000609 | | | 64-67 | | | 1 |
| 15510000654 | | 60 | 68-73 | 88 | 123 | 1,06 |

| Codice Code | F | D | DE | Z | Peso Weight |
|-------------|---------|----|-------|-----|-------------|
| | ISO 228 | mm | mm | mm | Kg |
| 15509000540 | G1-1/2 | 50 | 60-63 | 133 | 0,79 |
| 15509000559 | | | 64-67 | | 0,82 |
| 15509000611 | | 60 | 68-73 | 153 | 1 |