

# OPERATING & MAINTENANCE MANUAL



Long working life of the hydraulic components and correct use of the hydraulic systems can be assured only when maintenance is performed correctly and at regular intervals.

Filtration products will only be guaranteed if original MP Filtri replacements elements and spares are used.

In order to prevent the filter elements from collapsing due to excessive hydraulic pressure it is essential to use clogging & differential indicators that serve to inform the user of the need to change the cartridge.

Effective contamination control can be assured only by the correct use of clogging indicators.

## INSTALLATION

- A:** Check that the pressure value of the selected filter is higher than the system's maximum operating pressure (the maximum pressure value is shown on the dataplate).
- B:** Check that the filter body contains the filter cartridge.
- C:** Check that the operating fluid is compatible with the material of the body, cartridge and seals.
- D:** Secure the filter using the relevant threaded holes, to rigid brackets.  
Rigid installation makes it possible to unscrew the housing without introducing flexing of the hydraulic fittings, limiting any points of stress transfer.
- E:** Install the filter in an accessible position for correct and trouble-free maintenance and visibility.
- F:** Start the machine and check for absence of oil leak from the filter and relative fittings.
- G:** Repeat the visual inspection when the system arrives at the operating temperature of the oil.

## MAINTENANCE

- A:** All maintenance operations must be performed only by suitably trained personnel.
- B:** The hydraulic system must be depressurised before performing maintenance operations (except for duplex filter).
- C:** Maintenance must be carried out using suitable tools and containers to collect the fluid contained in the filter body.  
Spent fluids must be disposed of in compliance with statutory legislation.
- D:** Do not use naked flames during maintenance operations.
- E:** Use the utmost caution in relation to the temperature of the fluid. High temperature can lead to residual pressure with resulting undesirable movements of mechanical parts.

## CHANGING THE FILTER ELEMENT

- A:** The data on which the filter elements are changed must be entered in the machine datasheet.
- B:** Spare parts installed must be in compliance with the specifications given in the machine operating and maintenance manual.
- C:** Filter bodies and tools must be thoroughly cleaned prior to each maintenance operation.
- D:** After having opened the filter to change the filter element, check the condition of the seals and renew them if necessary.  
Clean thoroughly before reassembling.

**CHANGING THE FILTER ELEMENT**  
**FMP - FHP - FHM - FHB FILTERS**  
 with housing length 4 - 5

**1**

Depressurise the system and clean the filter.

**2**

Unscrew the oil drain plug and collect the fluid in a suitable container. When the filter has fully drained check the condition of the seals and if OK re-assemble the plug, tightening it fully down (Fig. 1).

Unscrew the cover (version P01) or housing (version P02) using the specific tools, and then extract the filter element (Fig. 2).

**3**

Collect the spent oil and cartridge in a suitable container and dispose of them in compliance with statutory legislation.

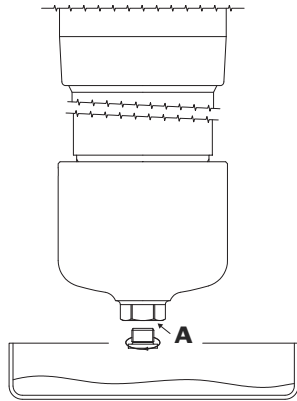

Fig. 1

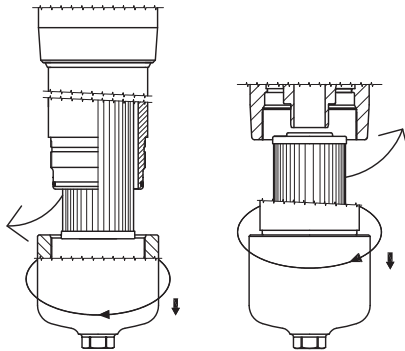

Fig. 2

**!!! WARNING !!!**

**4**

To avoid damaging the components, check the cover threads (version P01) or the housing threads (version P02) and the seals thoroughly; check also the housing (version P01) or head threads (version P02). Check the condition of the seals when changing the seals lubricate the new seals with operating fluid prior to installation (Fig. 3).

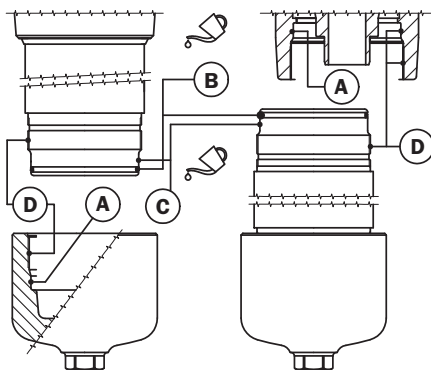

Fig. 3

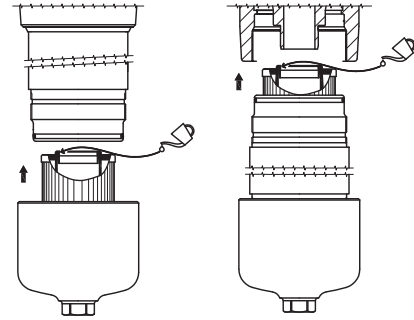

Fig. 4

**5**

Lubricate the filter element seal with the operating fluid prior to installation (Fig. 4).

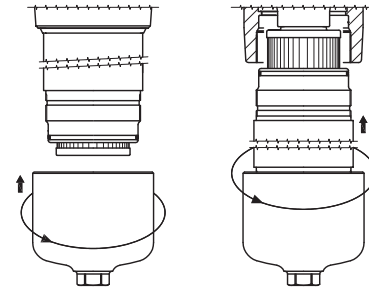

Fig. 5

**6**

Screw the cover onto the housing (version P01), or the housing onto the head (version P02) using the correct tool.

**WARNING:**

Screw the cover / housing fully home on the housing  
**“ DO NOT OVER - TIGHTEN ”**

**7**

Start the machine and check for the absence of leaks. Repeat the check when the machine has reached its operating temperature.

.....

.....

.....

.....

.....

.....

.....

.....

.....

.....

.....

## CHANGING THE FILTER ELEMENT ON FHF FILTERS

**1**

Depressurise the system and clean the filter.

**2**

Unscrew the air vent plug (item A) and open the oil drain connection (item B), collect the fluid in a suitable container (Fig. 1).

When the operation is finished check the condition of the seals and if OK re-assemble plug (item A) and drain plug tightening both fully down.

Unscrew the cover using the specific tools and extract the filter element (Fig. 2).

**3**

Collect the spent oil and cartridge in a suitable container and dispose of them in compliance with statutory legislation.

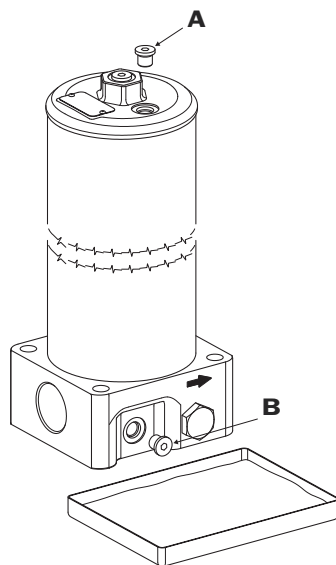

Fig. 1

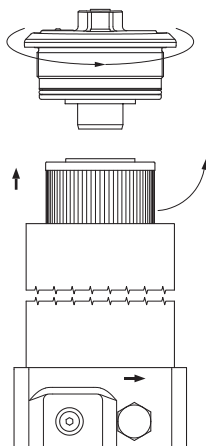

Fig. 2

**!!! WARNING !!!**

**4**

To avoid damaging the components check the cover threads and the seals thoroughly; check also the housing-thread. Check the condition of the seals when changing the seals lubricate the new seals with operating fluid prior to installation (Fig. 3).

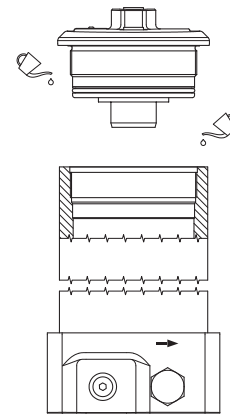

Fig. 3

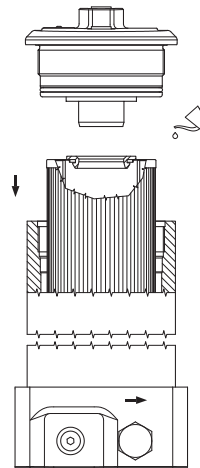

Fig. 4

**5**

Lubricate the filter element seal with the operating fluid prior to installation (Fig. 4).

**6**

Screw the cover into the housing using the correct tool.

**WARNING:**

Screw the cover fully home into the housing  
“ **DO NOT OVER - TIGHTEN** ”

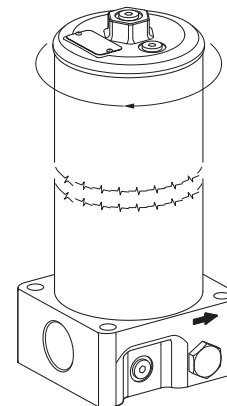

Fig. 5

**7**

Start the machine and bleed the air by unscrewing (max. one turn) the plug (item A). When the operation is terminated screw the plug fully down and check for the absence of leaks. Repeat the check when the machine has reached its operating temperature.

## CHANGING THE FILTER ELEMENT ON FHD 021 - 051 - 326 - 333 FILTERS

**1**

Depressurise the system and clean the filter.

**2**

Before turning the valve from housing B to housing A, open the \* balancing valve (item C) by turning it counterclockwise.

Bleed the air through the plug (item A1), the screw must be turned through a maximum of one revolution.

After bleeding the air re-tighten the vent plug and close the balancing valve (item C) by turning it clockwise.

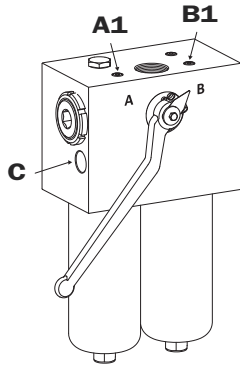
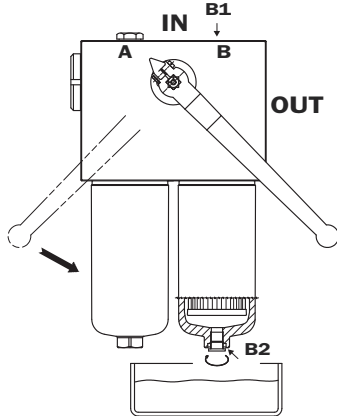

**Fig. 1**

**3**

Turn handle to divert the oil flow from housing B to housing A (Fig. 2). Unscrew the air vent plug (item B1) and open the oil drain connection (item B2) collecting the fluid in a suitable container. When the operation is finished check the condition of the seals and if OK re-assemble on the plug (item B2) tightening it fully down and re-tighten the the air vent connection (item B1).

Unscrew housing (B) using the appropriate tools and extract the filter element (Fig. 3).



**Fig. 2**

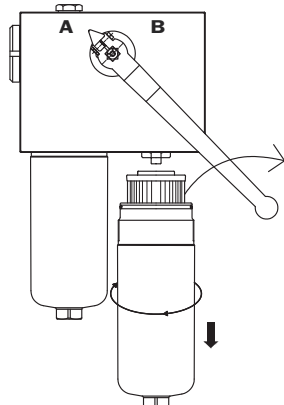

**Fig. 3**

**4**

Collect the spent oil and cartridge in a suitable container and dispose of them in compliance with statutory legislation.

## !!! WARNING !!!

**5**

To avoid damaging the components check the thread of the housing and the seals thoroughly; check also the thread of the head. Check the condition of the seals when changins the seals lubricate the new seals with operating fluid prior to installation (Fig. 4).

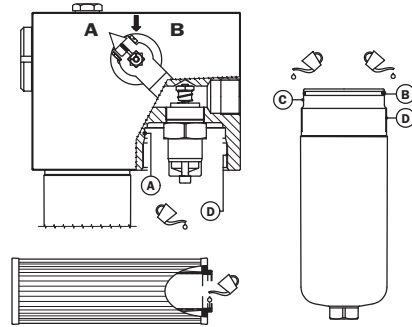

**Fig. 4**

**6**

Lubricate the filter element seal with the operating fluid prior to installation (Fig. 4).

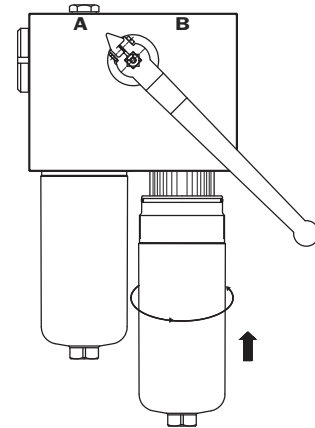

**Fig. 5**

**7**

Screw the housing onto the head using the correct tool.

### WARNING:

Screw the housing fully home on the housing  
“ **DO NOT OVER - TIGHTEN** ”

Open the balancing valve\* (item C) by turning it counterclockwise.

Bleed the air through the plug (item B1), the screw must be turned through a maximum of one revolution.

After bleeding the air re-tighten the vent plug and close the balancing valve\* (item C) by turning it clockwise.

Check for the absence of leaks.

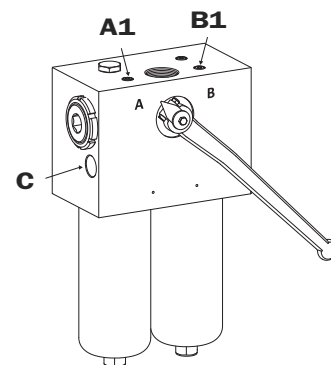

**Fig. 6**

**8**

Repeat the check when the machine has reached its operating temperature.

\* The balancing valve is not present in version FHD 021.

## CHANGING THE FILTER ELEMENT ON FHD 333 FILTERS HOUSING

### Length 4

**1**

Depressurise the system and clean the filter.

**2**

Before turning the valve from housing B to housing A, open the balancing valve (item C) by turning it counterclockwise.

Bleed the air through the plug (item A1), the screw must be turned through a maximum of one revolution. After bleeding the air re-tighten the vent plug and close the balancing valve (item C) by turning it clockwise.

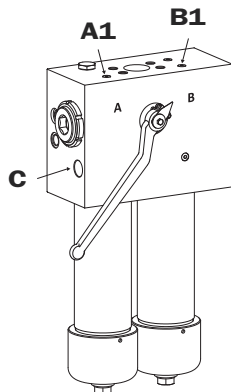
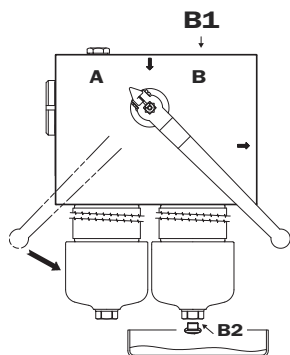

**Fig. 1**

**3**

Turn handle to divert the oil flow from housing B to housing A. Unscrew the air vent plug (item B1) and open the oil drain connection (item B2) collecting the fluid in a suitable container. When the operation is finished check the condition of the seals and if OK re-assemble on the plug (item B2) tightening it fully down and close their vent connection (item B1).

Unscrew the cover (version P01) using the appropriate tools and extract the filter element (Fig. 3).



**Fig. 2**

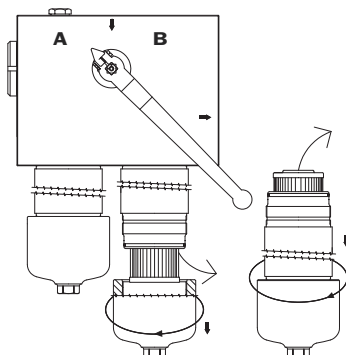

**Fig. 3**

**4**

Collect the spent oil and cartridge in a suitable container and dispose of them in compliance with statutory legislation.

## !!! WARNING !!!

**5**

To avoid damaging the components check the cover threads (version P01) or the housing threads (version P02) and the seals thoroughly; check also the housing threads (version P01) or the head threads (version P02).

Check the condition of the seals when changing the seals lubricate the new seals with operating fluid prior to installation (see fig. 4).

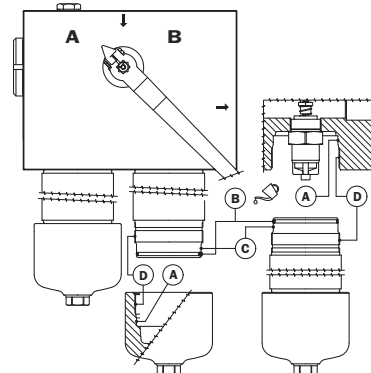

**Fig. 4**

**6**

Lubricate the filter element seal with the operating fluid prior to installation (Fig. 5).

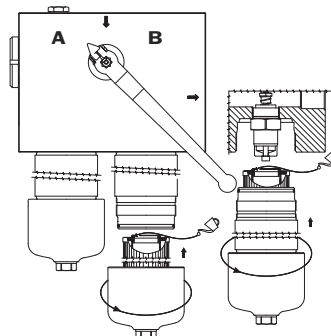

**Fig. 5**

**7**

Screw the cover onto the housing (version P01), or the housing onto the head (version P02) using the correct tool.

### WARNING:

Screw down the cover / housing fully home into the housing

### “ DO NOT OVER - TIGHTEN ”

Open the balancing valve\* (item C) by turning it counterclockwise. Bleed the air by means of plug (item B1), the screw must be turned through a maximum of one revolution.

After bleeding the air refit the vent plug and close the balancing valve\* (item C) by turning it clockwise. Check for the absence of leaks.

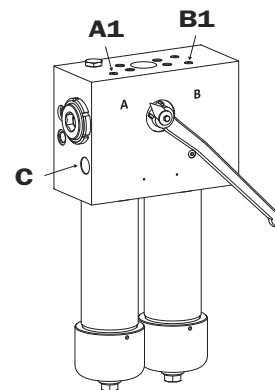

**Fig. 6**

**8**

Repeat the check when the machine has reached its operating temperature.